

Tecnología Aplicada
a la Información

1-Wire® Switch

TAI8555

Features

- 1-Wire® controlled latched Relay.
- NO and NC Relay outputs @ 1 amp.
- 0V-12V feedback input.
- No extra power supply required.
- Dallas Semiconductors DS2406 based.
- Pass through 1-Wire® network connection.
- Available option with Dallas Semiconductors TAG-ID standard for electronic identification of function.
- Simple interconnect through RJ11 connectors.
- Available with optional DS18S20 temperature sensor.
- HF input protection protection with ferrite beads
- Unique 1-Wire address permits multiple sensors on network

Description

The 1-Wire Switch module allows control of resistive loads up to 1 amp.

Its unique address permits it to be individually identified, selected and controlled within a 1-Wire network.

In addition to the relay output the module has a separate input that can be used as an independent input or as a feedback input for the controlled device. .

The 0V to 12V input range of this input is protected by a series diode.



The connect to the controlled relay is via wire connectors.

Optionally, the device can include a DS18S20 or a DS2505 EPROM memory in which the parameters of the module are stored using the TAG-ID and TAG-XML specification

By choosing TB or TS versions, a DS18X20 temperature is included in the module. A DS18B20 for the TB option and a DS18S20 in case of the TS version respectively. For further information regarding the DS2406 or the TAG-ID standard, visit:

www.ibutton.com

or

www.dalsemi.com

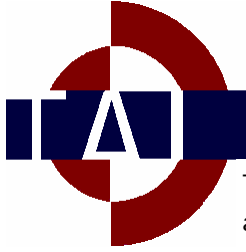

Tecnología Aplicada
a la Información

1-Wire® Switch

TAI8555

Specifications

- TQ2E-L2-5V relay 1 amp @ 30V max or 125 VCA max. resistive load
- Recovery time 1 sec
- Input status reported through DS2706 VCC Pin ,Input open equals “1”, input to ground equals “0”

Relay Control Table:

Pio A Channel flip-flop	Pio B Channel flip-flop	Relay Status	Con 1 Pin 1-Pin 2	Con 1 Pin 1-Pin3
-1-	-1-	No Change	Previous	Previous
-1-	-0-	Off	Closed	Open
-0-	-1-	On	Open	Closed
-0-	-0-	No Change	Previous	Previous

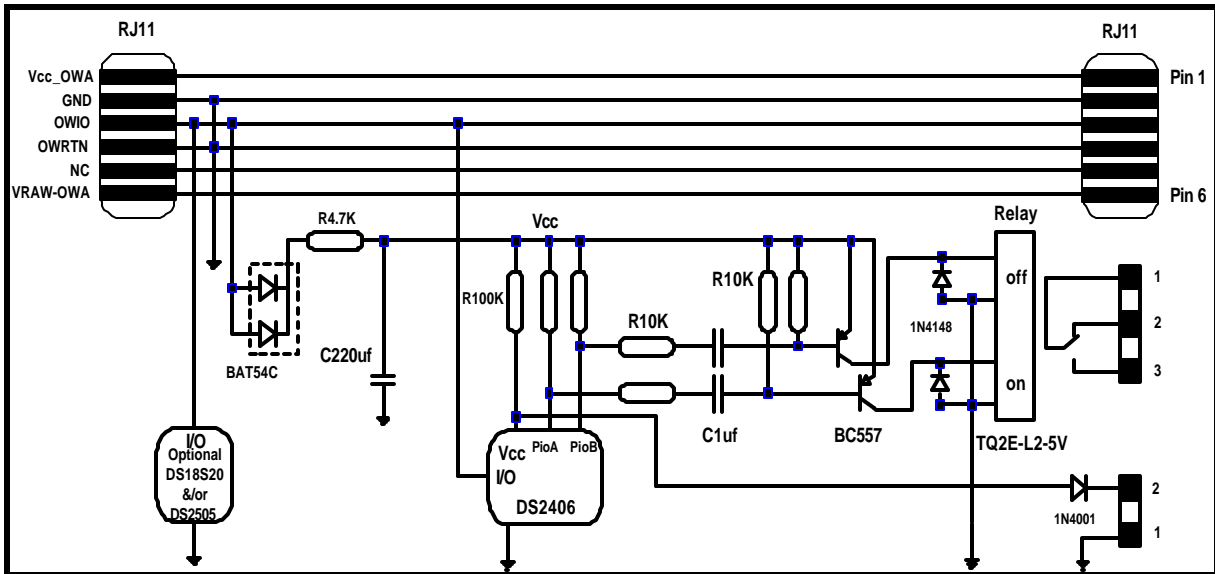

Automatización Aplicada a Gasolineras S.A. de C.V., Pino Suárez #271G, Col.Niños Héroes
Querétaro, 76010, Querétaro Tel/Fax +52(442)215-3166 e-mail:info@infoaag.com.mx, www.aag.com.mx

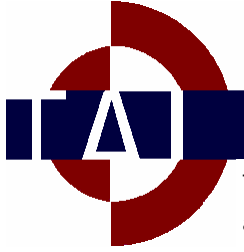

Tecnología Aplicada
a la Información

1-Wire® Switch

TAI8555

DS2505 file contents:

File TAGB.000

```

Byte 0-3  Part ID      : SWITC
Byte 4-7  Serial      : yyyy
Byte 8-12 Manufacturer : $ AAG
Byte 13-16 Mod. Function : $8555
Byte 17-19 Interface Type : $01
Byte 20-22 Hardware Rev. : $01
Byte 23-27 Date Code    : $ddddddd
  
```

File TAGD.000

```

{G: ParseData } [
  {D: Description (20)} TAI8555 1-Wire Switch
  {D: Manufacturer (3) } AAG
  {D: ManufacturerCode (5) } $ AAG
  {D: ClusterNum (4)} xxxxxxxx
  {D: ClusterRev(1)} 1
  {D: Enum (2)} yyyy
  {D: SecondsSince1970 (4) } dddddddd
  {G: OWCluster } [
    {G : OWActuator } [
      {D:Description ( 2 ) } ON
      {D:OWNetAddress (8) } yyyyyyxxxxxxxxxyy
      {D:ChannelMask(1)}3
      {D:ChannelState(1)}2
      {D:AccessMethod (1)} AM_SWITCH_2406
    ]
    {G : OWActuator } [
      {D:Description (3) } OFF
      {D:OWNetAddress (8) } yyyyyyxxxxxxxxxyy
      {D:ChannelMask(1)}3
      {D:ChannelState(1)}1
      {D:AccessMethod (1)} AM_SWITCH_2406
    ]
  ]
]
  
```

File TAGX.000

```

<?xml version="1.0" encoding="UTF-8"?>
<cluster name="TAI8555 Switch">
  <actuator addr="###...####" type="Switch">
    <label>Turn On</label>
    <max>On</max>
    <min>Off</min>
    <channel>0</channel>
    <init>1</init>
  </actuator>
  <actuator addr="###...####" type="Switch">
    <label>Turn off</label>
    <max>On</max>
    <min>Off</min>
    <channel>1</channel>
    <init>1</init>
  </actuator>
</cluster>
  
```

Ordering information:

TAI8555-WW-X

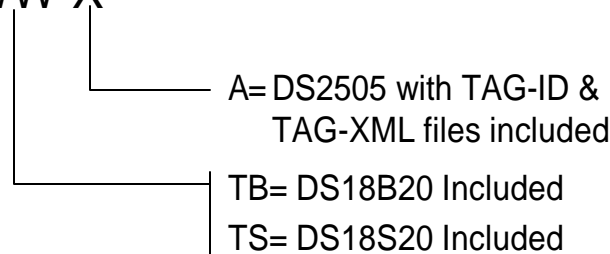

Important:

This product is not designed, intended or authorized for use as components in systems intended for surgical implant into the body, or other applications intended to support or sustain life, or for any other application in which the failure of a product of could create a situation where personal injury or death may occur.

1-Wire® is a trademark of the Dallas Semiconductor . Third-party product and brand names may be trademarks or registered trademarks of their respective owners