

PCX-3008

8 channel Isolated D/A

Output Card

Copy Right Notice

The information in this manual is subject to change without prior notice in order to improve reliability, design and function and DOES not represent a commitment on the part of the manufacturer. No part of this manual may be reproduced, copied, or transmitted in any form without the prior written permission of manufacturer.

Acknowledgment

Products mentioned in this manual are mentioned for identification purpose only. Products names appearing in this manual may or may not be registered trademarks or copyright of their respective companies

Printed Jan. 2002 Rev 1.1

Table of Contents

Chapter 1 Introduction	5
1.1 Introduction.....	6
1.2 Features.....	6
1.3 Applications.....	6
1.4 Specifications.....	7
1.5 Software Supporting.....	8
1.6 Programming Library.....	8
Chapter 2 Installation	9
2.1 What You Have.....	10
2.2 Unpacking.....	10
2.3 Hardware Installation Outline.....	10
2.4 Installation Procedures.....	11
2.5 Device Installation for Windows Systems.....	11
2.6 PCB Layout.....	12
2.7 Connector Pin Assignment of PCX-3008.....	13
Chapter 3 Jumper setting	15
3.1 Card number setting.....	16
3.2 Analog output setting.....	17
Chapter 4 Registers Format	19
4.1 PCI PnP Registers.....	20
4.2 Reset control registers.....	20
4.3 Digital Input Register Address Map.....	21
4.4 Digital Output Register.....	21
4.5 Analog output registers.....	22
Chapter 5 Operation Theorem	23
5.1 Isolated Digital Input channels.....	24
5.2 Isolated Digital output channels.....	25
5.3 Voltage Output.....	25
Chapter 6 Libraries	27
6.1 Libraries Installation.....	28
6.1.1 How to use the DOSDAQH.LIB in DOS.....	28
6.1.2 How to use the PCIDAQ.DLL s in Windows.....	29
6.2 Summary of function calls.....	30
6.3 W_3008_Open.....	31
6.4 W_3008_GetCardsID.....	32
6.5 W_3008_GetBusSlot.....	33
6.6 W_3008_Version.....	34

6.7 W_3008_Close.....	35
6.8 W_3008_Read_Di.....	36
6.9 W_3008_Write_Do.....	37
6.10 W_3008_Read_Do.....	38
6.11 W_3008_Set_Do_Bit.....	39
6.12 W_3008_Reset_Do_Bit.....	40
6.13 W_3008_DA.....	41
Chapter 7 PI-837 Terminal board	43
7.1 Main features.....	43

Chapter 1

Introduction

1.1 Introduction

The PCx-3008 is an isolated digital-to-analog output card for the PCI bus. It provides eight 12-bit analog output channels with isolation protection of 2500 V_{DC} between the outputs and the PCI bus. The PCX-3008 series includes three cards:

- ◆ PCX-3008: Isolated 8-CH voltage output card
- ◆ PCX-3008-2: Isolated 2-CH voltage and current output card
- ◆ PCX-3008-4: Isolated 4-CH voltage output card

Each of channel has: (1) bipolar $\pm 10V$ voltage outputs; (2) unipolar 0~+10V voltage output. The DA chip is the DAC-2518AP that is a state-of-the-art, fully monotonic, digital to analog converter. This device employs ultra-stable nichrome (NiCr) thin-film resistors to provide monotonicity, low distortion, and low differential linearity error over long period of time.

When the system is hot reset (the power is not shut off), the PCX-3008 can still retain the last analog output settings and values. This practical function eliminates danger caused by mis-operation during unexpected system resets.

1.2 Features

- ◆ 32-bit PCI-Bus, Plug and Play, complies with PCI local bus
- ◆ 8-CH 12-bit voltage output
- ◆ Fully isolation protection from PC power to external device
- ◆ 2500V_{rms} isolation voltage
- ◆ Unipolar or bipolar voltage output range
- ◆ On board DC-to-DC converter provide voltage and current source
- ◆ 8 Isolated digital input channels
- ◆ 8 Isolated digital output channels

1.3 Applications

- ◆ Process control
- ◆ Programmable voltage source
- ◆ Servo control
- ◆ Industrial Process Control
- ◆ Pressure / Temperature Transmitter
- ◆ Servo Control

1.4 Specifications

◆ D/A Output

Channels: 8 isolated D/A channels

Converter: DAC2518AP or equivalent

Resolution: 12 bits no missing code (11-bit guarantee)

Output ranges: Unipolar: -10V ~ +10 V, 0 ~ +10 V

Settling time: 16 μ second (-10V to +10V)

Accuracy: $\pm 0.024\%$

Differential Linearity Error: $\pm 0.002\%$ Full Scale Range

Data Transfer: Programmed I/O

Output initial status: 0V (after RESET or POWER-ON)

Isolation voltage: 2500 V_{DC} between the outputs and the PCI bus

Temperature drift: Typical: 10 PPM/ $^{\circ}$ C (0 ~ 60 $^{\circ}$ C)

Maximun: 20 PPM/ $^{\circ}$ C (0 ~ 60 $^{\circ}$ C)

Output current: ± 5 mA max.

◆ Digital Input

Numbers of digital input channel: 8-isolated input channel

Photo isolator: PC814 or equivalent

Isolation voltage: 5000Vrms

Input voltage: up to 34Vdc

*Logic "L": 0~3.0V

*Logic "H": 3.2~34V

Input resistance: 4.7K Ω @ 0.5W.

◆ Digital Output

Numbers of digital output channel: 8-isolated output channel

Photo isolator: PC817 or equivalent

Isolation voltage: 5000Vrms

Output type: Photo-coupler transistors, open collector up to 35Vdc

Sink current: 50mA maximum

◆ Power consumption

+5 V @ 350 mA (typical), 500mA (Max.)

+12V @ 200 mA (typical), 350mA (Max.)

◆ Physical

Connector: 37-pin D-type connector

Dimensions: 175 x 100 mm (6.9" x 3.9")

◆ Environment

Operating temperature: 0 ~ +60 $^{\circ}$ C (32 ~ 140 $^{\circ}$ F)

Storage temperature: -20 ~ +70 $^{\circ}$ C (-4 ~ 158 $^{\circ}$ F)

Operating humidity: 5 ~ 95 % RH non-condensing

MTBF: over 71,280 hrs @ 25 $^{\circ}$ C, grounded, fix environment

1.5 Software Supporting

Inlog provides versatile software drivers and packages for users' different approach to built-up a system. We not only provide programming library such as DLL for many Windows systems, but also provide drivers for many software package such as LabVIEW™, InTouch™ and so on. All the software options are included in the provided CD.

1.6 Programming Library

The provided CD includes the function libraries for many different operating systems, including:

- ◆ **DOS Library:** BorlandC/C++ and Microsoft C++, the functionsDescriptions are included in this user's guide.
- ◆ **Windows 98/2000/NT/Me/XP DLL:** For VB, VC++, BC5, the functionsDescriptions are included in this user's guide.
- ◆ **Windows 98/2000/NT/Me/XP ActiveX:** For Windows's applications
- ◆ **LabVIEW ® Driver:** Contains the VIs, which are used to interface with NI's LabVIEW ® software package. Supporting Windows 95/98/NT/2000. The LabVIEW ® drivers are free shipped with the board.
- ◆ **InTouch Driver:** Contains the InTouch driver which support the Windows 98/2000/NT/XP. The The InTouch ® drivers are free shipped with the board.

Chapter 2

Installation

This chapter describes how to install the PCX-3008 card. Please follow the follow steps to install the PCX-3008 card.

2.1 What You Have

In addition to this *User's Manual*, the package includes the following items:

- ◆ PCX-3008 board
- ◆ Driver/utilities CD
- ◆ This user's manual

If any of these items is missing or damaged, contact the dealer from whom you purchased the product. Save the shipping materials and carton in case you want to ship or store the product in the future

2.2 Unpacking

Your PCX-3008 card contains sensitive electronic components that can be easily damaged by static electricity. The operator should be wearing an anti-static wristband, grounded at the same point as the anti-static mat. Inspect the card module carton for obvious damage. Shipping and handling may cause damage to your module. Be sure there are no shipping and handling damages on the module before processing.

After opening the card module carton, extract the system module and place it only on a grounded anti-static surface component side up. Again inspect the module for damage. Press down on all the socketed IC's to make sure that they are properly seated. Do this only with the module place on a firm flat surface.

2.3 Hardware Installation Outline

◆ PCI configuration

The PCI cards are equipped with plug and play PCI controller, it can request base addresses and interrupt according to PCI standard. The system BIOS will install the system resource based on the PCI cards' configuration registers and system parameters (which are set by system BIOS). Interrupt assignment and memory usage (I/O port locations) of the PCI cards can be assigned by system BIOS only. These system resource assignments are done on a board-by-board basis. It is not suggested to assign the system resource by any other methods.

◆ PCI slot selection

The PCI card can be inserted to any PCI slot without any configuration for system resource.

2.4 Installation Procedures

1. Turn off your computer.
2. Turn off all accessories (printer, modem, monitor, etc.) connected to your computer.
3. Remove the cover from your computer.
4. Setup jumpers on the card.
5. Before handling the PCI cards, discharge any static buildup on your body by touching the metal case of the computer. Hold the edge and do not touch the components.
6. Position the board into the PCI slot you selected.
7. Secure the card in place at the rear panel of the system.

2.5 Device Installation for Windows Systems

Once Windows 95/98/2000 has started, the Plug and Play function of Windows system will find the new PCX cards. If this is the first time to install PCX cards in your Windows system, you will be informed to input the device information source. Please refer to the **“Software Installation Guide”** for the steps of installing the device.

2.6 PCB Layout

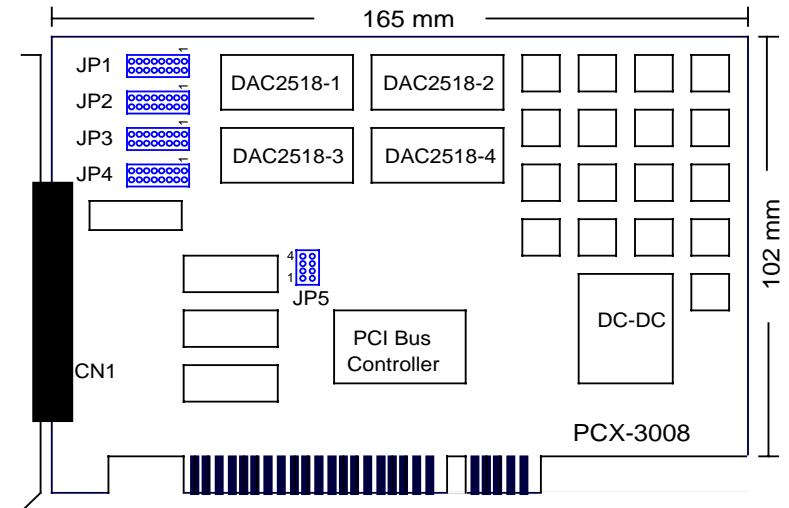

Where

- CN1: Analog outputs and digital I/O connector
- JP5: Card number jumper
- JP1: D/A channel #0~ #1 setting jumper
- JP2: D/A channel #2~ #3 setting jumper
- JP3: D/A channel #4~ #5 setting jumper
- JP4: D/A channel #6~ #7 setting jumper

2.7 Connector Pin Assignment of PCX-3008

The pin assignment of the 37-pin D-type connector is an isolated signal connector, 3008's pin assignment is as shown in Figure 2-1

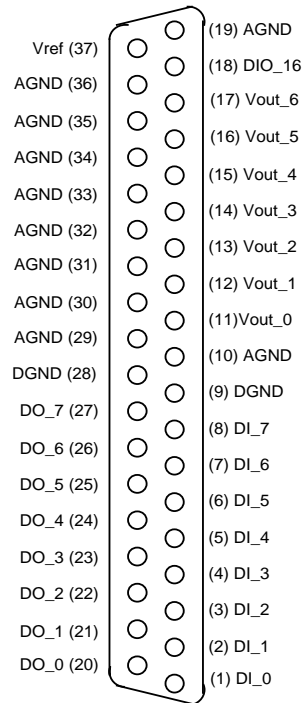

Figure 2-1 Pin Assignment of PCX-3008 connector CN1

Legend:

- ◆ **DI_n**: Isolated digital input channel #n
- ◆ **DO_n**: Isolated digital output channel #n
- ◆ **DGND**: Ground return path of isolated digital input and output channels
- ◆ **AGND**: Ground return path of isolated analog output channels
- ◆ **Vref**: D/A external reference voltage input





Chapter 3

Jumper setting

3.1 Card number setting

Maximum four PCX-3008 cards can be installed in system simultaneously with each has a unique card number.

A jumper called "JP5" (see page 12) on the card is used to set the card number starts from 1 to 4

JP5	Card number
	1 (default setting)
	2
	3
	4

3.2 Analog output setting

The PCX-3008's voltage output channels can be configured as different voltage range. Each output channel and its corresponding jumpers are listed as following tables.

- * PCX-3008: Channel_0(Vout_0) to Channel_7(Vout_7)
- * PCX-3008-4: Channel_0(Vout_0) to Channel_3(Vout_3)
- * PCX-3008-2: Channel_0(Vout_0) to Channel_1(Vout_1)

◆ Channel 0 and Channel 1(Vout_0 and Vout_1) setting (JP1)

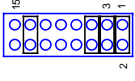
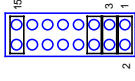
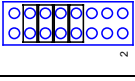
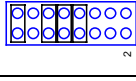
Channel NO.	(JP1) output mode and Range	
	Unipolar	
CH_0 and CH_1 (Vout_0 and Vout_1)	0V ~ +10V	0V ~ Vref
		
	Bipolar	
	-10V ~+10V	-Vref ~ +Vref
		

◆ Channel 2 and Channel 3(Vout_2 and Vout_3) setting (JP2)

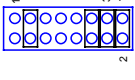
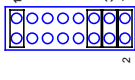
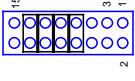
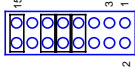
Channel NO.	(JP2) output mode and Range	
	Unipolar	
CH_2 and CH_3 (Vout_2 and Vout_3)	0V ~ +10V	0V ~ Vref
		
	Bipolar	
	-10V ~+10V	-Vref ~ +Vref
		

◆ Channel 4 and Channel 5(Vout_4 and Vout_5) setting (JP3)

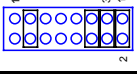
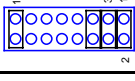
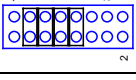
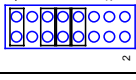
Channel NO.	(JP3) output mode and Range	
	Unipolar	
CH_4 and CH_5 (Vout_4 and Vout_5)	0V ~ +10V	0V ~ Vref
		
	Bipolar	
	-10V ~+10V	-Vref ~ +Vref
		

◆ Channel 6 and Channel 7(Vout_6 and Vout_7) setting (JP4)

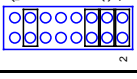
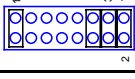
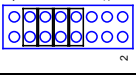
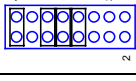
Channel NO.	(JP4) output mode and Range	
	Unipolar	
CH_6 and CH_7 (Vout_6 and Vout_7)	0V ~ +10V	0V ~ Vref
		
	Bipolar	
	-10V ~+10V	-Vref ~ +Vref
		

Note: PCX-3008 is pins compatible to the general purposed 37-pin screw terminal PI-837 which equipped with heavy-duty screw terminal

Chapter 4

Registers Format

This information is quite useful for the programmers who wish to handle the card by low-level programming. However, we suggest user have to understand more about the PCI interface then start any low-level programming. In addition, the contents of this chapter can help users understand how to use software driver to manipulate this card.

4.1 PCI PnP Registers

There are two types of registers: PCI Configuration Registers (PCR) and Peripheral Interface Bus (PIB). The PCR, which is compliant to the PCI-bus specifications, is initialized and controlled by the plug & play (PnP) PCI BIOS..

The PCI bus controller 'Tiger 100/320' is provided by Tigerjet Network Inc. (www.tjnet.com). For more detailed information of PIB, please visit Tigerjet technology's web site to download relative information. It is not necessary for users to understand the details of the PIB if you use the software library. The PCI PnP BIOS assigns the base address of the PIB.

The 3008 board registers are in 32-bit width. But only lowest byte (bit0~bit7) is used. The users can access these registers by only 32-bit I/O or 8-bit I/O instructions. The following sections show the address map, including descriptions and their offset addresses relative to the base address.

4.2 Reset control registers

The PCX-3008 is in inactive state when the system power on, and should be activated by set bit 0 of this register to "1" state

Address: Base + 000H

Attribute: Write only

Bit	7	6	5	4	3	2	1	0	State
Base+000H	0	0	0	0	0	0	0	0	Inactive (reset) state (Default)
Base+000H	0	0	0	0	0	0	0	1	Active state

♦ Bit 0 of this register should be set to "1" before using PCX-3008

4.3 Digital Input Register Address Map

There are 8 isolated digital input channels on PCX-3008, each bit of based address is corresponding to a signal on the digital input channel.

Address: BASE + 0C8H (port 0 only)

Attribute: read only

Bit	Port	7	6	5	4	3	2	1	0
Base+0C8H	0	DI_7	DI_6	DI_5	DI_5	DI_3	DI_2	DI_1	DI_0

4.4 Digital Output Register

There are total 8 digital output channels on the PCX-3008, each bit of based address is corresponding to a signal on the digital output channel.

Address: BASE + 0C8H (port 0 only)

Attribute: write

Bit	Port	7	6	5	4	3	2	1	0
Base+0C8H	0	DO_7	DO_6	DO_5	DO_5	DO_3	DO_2	DO_1	DO_0

Address: BASE + 0C4H (port 0 only)

Attribute: read back of digital output port

Bit	Port	7	6	5	4	3	2	1	0
Base+0C4H	0	DO_7	DO_6	DO_5	DO_5	DO_3	DO_2	DO_1	DO_0

4.5 Analog output registers

These registers control the operations of DAC2815 converters. For more detailed information of DAC2815, please visit BURR-BROWN Company's web site (www.burrbrown.com) to download relative information.

◆ Control register

Bit	7	6	5	4	3	2	1	0
Base+0C4H	LE	WR	CS3	CS2	CS1	CS0	A1	A0

◆ Data register

Bit	7	6	5	4	3	2	1	0
Base+0C0H	DA7	DA6	DA5	DA4	DA3	DA2	DA1	DA0

Chapter 5 Operation Theorem

5.1 Isolated Digital Input channels

The isolated digital input is open collector transistor structure. The input voltage range form 0V to 24V and input resistor is 4.7K ohms. The connection between outside signal and PCX-3008/AC is shown in Figure 4-2 and Figure 4-3

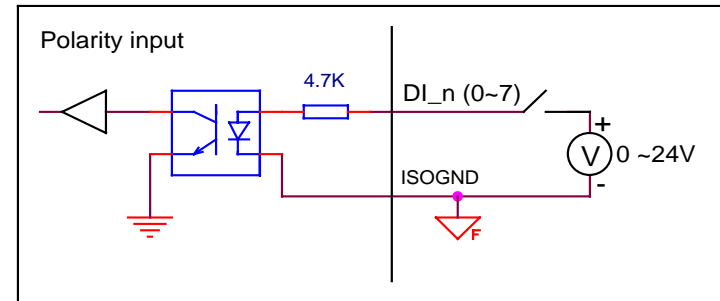

Figure 4-2 isolated digital inputs of PCX-3008

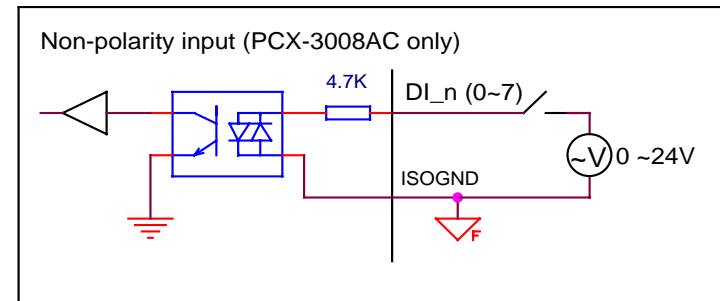

Figure 4-3 isolated digital inputs of PCX-3008AC

5.2 Isolated Digital output channels

The isolated digital output circuits are as following. The output is open collector type..

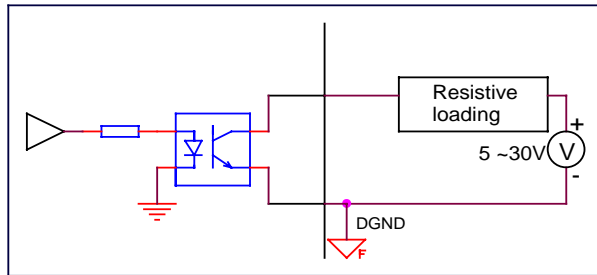

Figure 4-4 isolated digital output

5.3 Voltage Output

The DA converter 'DAC2815AP' is a 12-bits DAC. The voltage output range is jumper selectable by JP1~JP4. Please refer to section 3.2 for detail of the jumper setting. The user-defined voltage (Vref) is input from the DB-37 connector's pin #37.

The DA data format is 12-bits unsigned value for all channels, that is, the value is in binary format. Table 4-1 shows the relation between the digital value and the analog output voltage.

Mode	Hex value	Output voltage
0 ~ +10V	0xFFF (4095)	+9.99969V
	0x800 (2048)	+5.00000V
	0x000 (0000)	+0.00000V
-10V ~ +10V	0xFFF (4095)	+9.99969V
	0x800 (2048)	+0.00000V
	0x000 (0000)	-10.00000V
0V ~ Vref	0xFFF (4095)	+Vref
	0x800 (2048)	+Vref/2
	0x000 (0000)	0.00000V
-Vref ~ +Vref	0xFFF (4095)	+Vref
	0x800 (2048)	+0.0000V
	0x000 (0000)	-Vref

Table 4-1

Chapter 6

Libraries

This chapter describes the software library for operating this card. Only the functions in DOS library and Windows DLL are described. Please refer to the PCIDAQ function reference manual, which included in Inlog CD, for the descriptions of the Windows 98/NT/2000 DLL functions.

6.1 Libraries Installation

This section will show you how to install the software libraries DOSDAQH.LIB for DOS, or Windows 98 DLL, or PCIDAQ for Windows 98/NT/2000.

The device drivers and DLL functions of Windows 98/NT/2000 are included in the PCIDAQ. The Inlog CD also includes the detail examples and readme files

6.1.1 How to use the DOSDAQH.LIB in DOS

◆ For BC compiler

1. Large mode: Add `..\LIB\BC\DOSDAQ.LIB` in your project
2. Huge mode: Add `..\LIB\BC\DOSDAQH.LIB` in your project
3. Include DOSDAQ.H in your source file

◆ For MSC compiler

1. Large mode: Add `..\LIB\MSC\DOSDAQ.LIB` in your project
2. Huge mode: Add `..\LIB\MSC\DOSDAQH.LIB` in your project
3. Include DOSDAQ.H in your source file

◆ For TC compiler

1. Large mode: Add `..\LIB\TC\DOSDAQ.LIB` in your project
2. Huge mode: Add `..\LIB\TC\DOSDAQH.LIB` in your project
3. Include DOSDAQ.H in your source file

6.1.2 How to use the PCIDAQ.DLL s in Windows

♦ VC++6.0:

1. Add file './Include/PCIDAQ.H' in your project
2. In link page of menu project| setting, add './LIB/PCIDAQ.LIB' in the blank of Objects/Library Modules
3. Add this sentence "#include './Include/PCIDAQ.H' " to the head of your main file.

♦ Visual BASIC:

1. Add file './Include/Declare.bas' in your project.

♦ Delphi:

1. Add file './Include/Declare.pas' in your project
2. Add this sentence "uses Declare;" in the head of your unit.pas

♦ C++Builder:

1. Add file './Include/PCIDAQ.H' and './Lib/PCIDAQ_CB.lib' to your project
2. Add this sentence "#include './Include/PCIDAQ.H' " to head of your main file.

Note: For more information, please refer to program in directory './Example/'

6.2 Summary of function calls

Function	Description	page
W_3008_Open	Initial PCX-3008 card before using	31
W_3008_GetCardsID	Get PCI ID code of PCX-3008	32
W_3008_GetBusSlot	Get PCI bus and slot number occupied by PCX-3008	33
W_3008_Version	Get version number of PCIDAQ.DLL	34
W_3008_Close	Close PCX-3008 card before terminating program	35
W_3008_Read_Di	Read digital input port data (8-bit)	36
W_3008_Write_Do	Write data (8-bit) to digital output port	37
W_3008_Read_Do	Read back current value of digital output port	38
W_3008_Set_Do_Bit	Activate a bit of digital output port (output transistor ON)	39
W_3008_Reset_Do_Bit	De-activate a bit of digital output port (output transistor OFF)	40
W_3008_DA	Write data to D/A channel	41

6.3 W_3008_Open

Description:

Because the PCX-3008 is PCI bus architecture and meets the plug and play design, the IRQ and base_address (pass-through address) are assigned by system BIOS directly. PCX-3008 cards have to be initialized by this function before calling other functions.

Syntax:

C/C++(DOS)

```
WORD D_3008_Open (WORD cardNo);
```

C/C++ (Windows)

```
WORD W_3008_Open (WORD *ExistedCards);
```

Visual BASIC (Windows)

```
Function W_3008_Open (ByRef ExistedCards As Long) As Long
```

Delphi

```
Function W_3008_Open (var ExistedCards:Integer):Integer;
```

Argument:

cardNo: card number set by jumper on card (DOS only)

existCards: The number of installed PCX-3008 cards.(Windows only). This return value shows how many PCI-3008 cards are installed in your system.

Return Code:

Error code (Please refer to PCIDAQ.H or DOSDAQ.H)

6.4 W_3008_GetCardsID

Description:

Get the cards number that is set by jumper on cards.

Syntax:

C/C++(DOS)

```
void D_3008_GetCardsID(WORD *CardsIDArray);
```

C/C++(Windows)

```
WORD W_3008_GetCardsID (WORD *CardsIDArray);
```

Visual BASIC (Windows)

```
Function W_3008_GetCardsID (ByRef CardsIDArray As Long)
    As Integer
```

Delphi

```
Function W_3008_GetCardsID (var CardsIDArray:Word):Word;
```

Argument:

CardsIDArray: This array return card number of installed cards. You should define a 4 elements array, and then pass the array's pointer to this function.

Return Code:

CardIDArray[*n*]=TRUE if card number *n* exists

Error code (Please refer to PCIDAQ.H or DOSDAQ.H)

6.5 W_3008_GetBusSlot

Description:

Get the PCI bus and slot of the card

Syntax:

C/C++(DOS)

```
WORD D_3008_GetBusSlot (WORD cardNo, WORD *bus,WORD *slot);
```

C/C++ (Windows)

```
WORDW_3008_GetBusSlot (WORD cardNo, WORD *bus,WORD *slot);
```

Visual BASIC (Windows)

```
Function W_3008_GetBusSlot (ByVal cardNo As Long,  
    ByRef bus As Long, ByRef slot As Long) As Long
```

Delphi

```
Function W_3008_GetBusSlot (cardNo:Integer;  
    var bus:Integer;var slot:Integer):Integer;
```

Argument:

cardNo: Card number set by jumper on card

bus: Return PCI bus Number

slot: Return PCI slot Number of the bus

Return Code:

Error code (Please refer to PCIDAQ.H or DOSDAQ.H)

6.6 W_3008_Version

Description:

PCIDAQ.DLL driver drives the PCX-3008 cards. This function returns the version of PCIDAQ.DLL driver

Syntax:

C/C++(DOS)

```
Void D_3008_Version (char *version);
```

C/C++ (Windows)

```
Int W_3008_Version (void);
```

Visual BASIC (Windows)

```
Function W_3008_Version () As Long
```

Delphi

```
Function W_3008_Version ():Integer;
```

Argument:

version: This string pointer return the version of DOSDAQ.DLL (DOS only)

Return Code:

Return the version number (Windows only)

6.7 W_3008_Close

Description:

The IRQ and base_address of PCX-3008 (pass-through address) are assigned by system BIOS directly. This function should be called to release all system resource before terminate application program

Syntax:

C/C++(DOS)

```
WORD D_3008_Close (WORD cardNo);
```

C/C++ (Windows)

```
Void W_3008_Close (void);
```

Visual BASIC (Windows)

```
Function W_3008_Close ()
```

Delphi

```
Function W_3008_Close ();
```

Argument:

None

Return Code:

None

6.8 W_3008_Read_Di

Description:

This function is used to read data from digital input port. You can get 8-bit input data from PCX-3008 by calling this function.

Syntax:

C/C++(DOS)

```
WORD D_3008_Read_Di (WORD cardNo,WORD *DiData);
```

C/C++ (Windows)

```
WORD W_3008_Read_Di (WORD cardNo,WORD *DiData);
```

Visual BASIC (Windows)

```
Function W_3008_Read_Di (ByVal cardNo As Long,  
ByRef DiData As Long) As Long
```

Delphi

```
Function W_3008_Read_Di (cardNo:Integer;  
var DiData:Integer):Integer;
```

Argument:

cardNo: Card number set by jumper on card

DiData: Return digital input data

Return Code:

Error code (Please refer to PCIDAQ.H or DOSDAQ.H)

6.9 W_3008_Write_Do

Description:

This function is used to write data to output port. You can send 8-bit output data to PCX-3008 by calling this function.

Syntax:

C/C++ (DOS)

```
WORD D_3008_Read_Do (WORD cardNo,WORD *DoData);
```

C/C++ (Windows)

```
WORD W_3008_Write_Do (WORD cardNo,WORD Data);
```

Visual BASIC (Windows)

```
Function W_3008_Write_Do (ByVal cardNo As Long,  
    ByVal Data As Long) As Long
```

Delphi

```
Function W_3008_Write_Do(cardNo:Integer;  
    Data:Integer):Integer;
```

Argument:

cardNo: Card number set by jumper on card

Data: Data be written to output port

Return Code:

Error code (Please refer to PCIDAQ.H or DOSDAQ.H)

6.10 W_3008_Read_Do

Description:

This function is used to read current data of output port. You can read back 8-bit output data of PCX-3008 by calling this function.

Syntax:

C/C++ (DOS)

```
WORD D_3008_Read_Do (WORD cardNo,WORD *DoData);
```

C/C++ (Windows)

```
WORD W_3008_Read_Do (WORD cardNo,WORD *DoData);
```

Visual BASIC (Windows)

```
Function W_3008_Read_Do (ByVal cardNo As Long,  
    ByRef DoData As Long) As Long
```

Delphi

```
Function W_3008_Read_Do (cardNo:Integer;  
    var DoData:Integer):Integer;
```

Argument:

cardNo: Card number set by jumper on card

Data: Return current output data

Return Code:

Error code (Please refer to PCIDAQ.H or DOSDAQ.H)

6.11 W_3008_Set_Do_Bit

Description:

Set one digital output channel On (set output transistor ON)

Syntax:

C/C++(DOS)

```
WORD D_3008_Set_Do_Bit (WORD cardNo, WORDbitNo);
```

C/C++ (Windows)

```
WORD W_3008_Set_Do_Bit (WORD cardNo, WORDbitNo);
```

Visual BASIC (Windows)

```
Function W_3008_Set_Do_Bit (ByVal cardNo As Long,  
    ByVal bitNo As Long) As Long
```

Delphi

```
Function W_3008_Set_Do_Bit (cardNo:Integer;  
    bitNo:Integer):Integer;
```

Argument:

cardNo: Card number set by jumper on card

bitNo : Channel Number(0 to 7)

Return Code:

Error code (Please refer to PCIDAQ.H or DOSDAQ.H)

6.12 W_3008_Reset_Do_Bit

Description:

Set one digital output channel Off (set output transistor OFF)

Syntax:

C/C++ (DOS)

```
WORD D_3008_Reset_Do_Bit (WORD cardNo, WORD bitNo);
```

C/C++ (Windows)

```
WORD W_3008_Reset_Do_Bit (WORD cardNo, WORD bitNo);
```

Visual BASIC(Windows)

```
Function W_3008_Reset_Do_Bit (ByVal cardNo As Long,  
    ByVal bitNo As Long) As Long
```

Delphi

```
Function W_3008_Reset_Do_Bit (cardNo:Integer;  
    bitNo:Integer):Integer;
```

Argument:

cardNo: Card number set by jumper on card

bitNo: Channel Number(0 to 7)

Return Code:

Error code (Please refer to PCIDAQ.H or DOSDAQ.H)

6.13 W_3008_DA

Description:

Write data to D/A output channel

Syntax:

C/C++(DOS)

```
WORD D_3008_DA (WORD Card_No,WORD DAChannel,  
WORD DARange,float DAData);
```

C/C++(Windows)

```
WORD W_3008_DA (WORD Card_No,WORD DA_Ch,WORD DA_Range,  
float DAData);
```

Visual BASIC (Windows)

```
Function W_3008_DA (ByVal Card_No As Long, ByVal DA_Ch As Long,  
ByVal DA_Range as Long,ByVal DADData As Single)  
As Long
```

Delphi

```
Function W_3008_DA (Card_No: Integer; DA_Ch:Integer;  
DA_Range: Integer; DADData: Single):Integer;
```

Argument:

cardNo: Card number set by jumper on card

DA_Ch: DA Output Channel (0 to 7)

DA_Range: DA Output Range:0=0V~10V; 1=-10V~+10V

DADData: Voltage of DA Conversion (0.000V~10.00V or -10.00V~+10.00V)

Return Code:

Error code (Please refer to PCIDAQ.H or DOSDAQ.H)

Chapter 7

PI-837 Terminal board

PI-837 Screw-terminal termination board features one 37-pin D-type connector for easy maintenance, wiring, and installation. It provides 37 channels that are accessed through a 37-pin D-type connector.

7.1 Main features

- ◆ Low-cost screw-terminal board for the all PCX series with 37-pin D-type connector
- ◆ Reserved space for signal-conditioning circuits such as low-pass filter, voltage attenuator and current shunt
- ◆ Industrial type termination blocks permit heavy-duty and reliable signal connections
- ◆ Table-top mounting using nylon standoffs. Screws and washers provided for panel or wall mounting
- ◆ Dimensions: 80mm (W) x 181mm (H)

