PCX-2026
Multi-function DAS
Cards
User's Guide

Copy Right Notice

The information in this manual is subject to change without prior notice in order to improve reliability, design and function and DOES not represent a commitment on the part of the manufacturer. No part of this manual may be reproduced, copied, or transmitted in any form without the prior written permission of manufacturer.

Acknowledgment

Products mentioned in this manual are mentioned for identification purpose only. Products names appearing in this manual may or may not be registered trademarks or copyright of their respective companies

Printed Aug. 2002 Rev 1.0

Table of Contents

Chapter 1 Introduction	2
1.1 Features.....	3
1.2 Applications	3
1.3 Specifications.....	4
1.4 Software Supporting	6
1.5 Programming Library	6
Chapter 2 Installation	8
2.1 What You Have.....	9
2.2 Unpacking.....	9
2.3 Hardware Installation Outline.....	9
2.4 PCB outline.....	10
Chapter 3 Connector Pin Assignments	12
3.1 Analog input/output & digital input/output (CN2).....	13
3.2 Timer/counter #0 (JP5).....	13
Chapter 4 Jumper Setting	14
4.1 Card number setting	15
4.2 Analog Signal Input (A/D) Type selection	15
4.3 Analog Input Polarity and Range selection.....	16
4.4 Analog output (D/A) range selection.....	16
Chapter 5 Registers Format	18
5.1 PCI PnP Registers.....	19
5.2 PCI controller register address map	19
5.3 Digital Input Register Address Map	20
5.4 Digital Output Register.....	20
5.5 Read FIFO data register	20
5.6 Read FIFO status register	21
5.7 A/D control register	21
5.8 A/D control status register	22
5.9 Interrupt Control and Read back Register	22
5.10 Software Trigger Register	23
5.11 Hardware Interrupt Clear Register.....	23
5.12 Clear scan register.....	23
5.13 D/A control and data registers	23
5.14 Timer/Counter Register.....	24
5.15 High Level Programming	24

Chapter 6 Operation Theorem	26
6.1 Digital Input Channels	27
6.2 Isolated Digital Output Channels.....	27
6.3 A/D Signal Source Control.....	28
6.4 A/D Trigger Source Control	31
6.5 A/D Data Transfer Modes	31
6.6 Interrupt Control.....	32
6.7 Timer/Counter Operation.....	33
Chapter 7 Libraries	34
7.1 How to use the DOSDAQH.LIB in DOS.....	35
7.2 How to use the PCIDAQH.DLL in Windows	35
7.3 Open PCX-2026 card	36
7.4 Get card number setting	37
7.5 Get Version of PCIDAQH.DLL or DOSDAQH.LIB.....	38
7.6 Close PCX-2026 card before exiting	39
7.7 Read data from digital input port	40
7.8 Get the PCI bus and slot number of the card	41
7.9 Write data to digital output port	42
7.10 Read back current value of the digital output port.....	43
7.11 Set a bit of digital output port.....	44
7.12 Reset a bit of digital output port.....	45
7.13 Initial software trigger mode	46
7.14 Single A/D channel acquire	47
7.15 Multiple A/D channels acquire	48
7.16 Initial interrupt trigger mode.....	49
7.17 Start A/D auto scan.....	51
7.18 Get A/D scanning data.....	52
7.19 Stop auto scan.....	53
7.20 Start interrupt single channel conversion.....	54
7.21 Start Interrupt Multiple channel conversion	55
7.22 Stop A/D interrupt	56
7.23 Check A/D Interrupt status.....	57
7.24 Perform A/D Data Transfer	58
7.25 Initial and start timer/counter #0	59
7.26 Read timer/counter #0.....	60
7.27 Stop timer/counter #0	61
7.28 Write data to DA.....	62
Chapter 8 Calibration & Utilities	64
8.1 Calibration	64

8.2	VR Assignment	64
Chapter 9	PI-837 Terminal board.....	66
9.1	Main features	66

Chapter 1

Introduction

The PCX-2026 products are multi-function data acquisition cards.. The PCX-2026 is ideal for data logging and signal analysis applications in medical, process control

1.1 Features

The PCI-2026 PCI Bus Advanced Data Acquisition card provides the following advanced features:

- ◆ 32-bit PCI-Bus
- ◆ 12-bit analog input resolution
- ◆ On-board A/D FIFO memory
- ◆ Auto-scanning channel selection
- ◆ Up to 110Khz A/D sampling rates
- ◆ 16 single-ended or 8 differential analog input channels
- ◆ Bipolar or unipolar input signals
- ◆ Programmable gain of x1, x2, x4, x8
- ◆ On-chip sample & hold
- ◆ Two 12-bit monolithic multiplying analog output channels
- ◆ 8 digital output channels
- ◆ 8 digital input channels
- ◆ 3 independent programmable 16-bit down counters
- ◆ Three A/D trigger modes: software trigger, programmable pacer trigger
- ◆ Integral DC-to-DC converter for stable analog power source
- ◆ 37-pin D-type connector for PCI-2026
- ◆ Half-size PCB

1.2 Applications

- ◆ Industrial and laboratory ON/OFF control
- ◆ Energy management
- ◆ Annunciation
- ◆ 16 TTL/DTL compatible digital input channels
- ◆ Security controller
- ◆ Product test
- ◆ Event and frequency counting
- ◆ Waveform and pulse generation

1.3 Specifications

Analog Input (A/D)

- ◆ Converter: ADS774 or equivalent, successive approximation type
- ◆ Resolution: 12-bit
- ◆ Numbers of Input Channel: 16 single-ended or 8 differential
- ◆ Input Range: (Programmable)
 - Bipolar: $\pm 10V$, $\pm 5V$, $\pm 2.5V$, $\pm 1.25V$, $\pm 0.625V$
 - Unipolar: $0\sim 10V$, $0\sim 5V$, $0\sim 2.5V$, $0\sim 1.25V$
- ◆ Conversion Time: 8 μ sec
- ◆ Throughput: 110KHz multiplexing (maximum)
- ◆ Analog Input Over-voltage Protection: Continuous $\pm 35V$ max.
- ◆ Accuracy:
 - ◆ GAIN = 1 0.01% of FSR ± 1 LSB
 - ◆ GAIN = 2, 4 0.02% of FSR ± 1 LSB
 - ◆ GAIN = 8 0.04% of FSR ± 1 LSB
- ◆ Input Impedance: 10 M Ω
- ◆ Trigger Modes: Software, Timer Pacer
- ◆ Data Transfer Modes: Program control, Interrupt
- ◆ FIFO Depth: 1K words

Analog Output (D/A)

- ◆ Numbers of Output Channel: 2 double-buffered analog output
- ◆ Resolution: 12-bit
- ◆ Output Range: (unipolar) $0\sim 10V$ or (bipolar) $-10V \sim +10V$
- ◆ Converter: DAC2815 or equivalent, monolithic multiplying
- ◆ Settling Time: 30 μ sec
- ◆ Linearity: $\pm 1/2$ bit LSB
- ◆ Output Driving Capability: $\pm 5mA$ max.

Digital I/O (DIO)

- ◆ Numbers of channels: 8 inputs and 8 outputs ,TTL compatible
- ◆ Input Voltage:
 - Low: Min. 0V. Max. 0.8V
 - High: Min. +2.0V
- ◆ Input Load:
 - Low: +0.5V @ -0.2mA max.
 - High: +2.7V @+20mA max.
- ◆ Output Voltage:
 - Low: Min. 0V; Max. 0.4V
 - High: Min. +2.4V
- ◆ Driving Capacity:
 - Low: Max. +0.5V at 8.0mA (Sink)
 - High: Min. +2.7V at 0.4mA (Source)

Programmable Counter

- ◆ Timer / Counter Device: 8254
- ◆ A/D pacer timer: 32-bit timer (two 16-bit counter cascaded together) with a 2MHz time base
- ◆ Pacer Frequency Range: 0.00046 Hz ~ 100K Hz
- ◆ Counter: One 16-bit counter with a 2MHz time base

General Specifications

- ◆ Connector: 37-pin D-type connector
- ◆ Operating Temperature: $0^{\circ}C \sim 60^{\circ}C$
- ◆ Storage Temperature: $-20^{\circ}C \sim 80^{\circ}C$
- ◆ Humidity: 5 ~ 95%, non-condensing
- ◆ Power Requirement: +5 V @ 460 mA typical
- ◆ PCB Dimension: 102mm(H) X 165mm(L)

1.4 Software Supporting

Inlog provides versatile software drivers and packages for users' different approach to built-up a system. We not only provide programming library such as DLL for many Windows systems, but also provide drivers for many software package such as LabVIEW™, InTouch™ and so on. All the software options are included in the provided CD.

1.5 Programming Library

The provided CD includes the function libraries for many different operating systems, including:

- ♦ **DOS Library:** Borland C/C++ and Microsoft C++, the functions descriptions are included in this user's guide.
- ♦ **Windows 98/2000/NT/Me/XP DLL:** For VB, VC++, BC5, the functions descriptions are included in this user's guide.
- ♦ **Windows 98/2000/NT/Me/XP ActiveX:** For Windows's applications
- ♦ **LabVIEW ® Driver:** Contains the VIs, which are used to interface with NI's LabVIEW ® software package. Supporting Windows 95/98/NT/2000. The LabVIEW ® drivers are free shipped with the board.
- ♦ **InTouch Driver:** Contains the InTouch driver which support the Windows 98/2000/NT/XP. The The InTouch ® drivers are free shipped with the board.

Chapter 2

Installation

This chapter describes how to install the PCX-2026 card. Please follow the follow steps to install the PCX-2026 card.

2.1 What You Have

In addition to this *User's Manual*, the package includes the following items:

- ◆ PCX-2026 board
- ◆ Driver/utilities CD
- ◆ This user's manual

If any of these items is missing or damaged, contact the dealer from whom you purchased the product. Save the shipping materials and carton in case you want to ship or store the product in the future

2.2 Unpacking

Your PCX-2026 card contains sensitive electronic components that can be easily damaged by static electricity. The operator should be wearing an anti-static wristband, grounded at the same point as the anti-static mat. Inspect the card module carton for obvious damage. Shipping and handling may cause damage to your module. Be sure there are no shipping and handling damages on the module before processing.

2.3 Hardware Installation Outline

◆ PCI configuration

The PCI cards are equipped with plug and play PCI controller, it can request base addresses and interrupt according to PCI standard. The system BIOS will install the system resource based on the PCI cards' configuration registers and system parameters (which are set by system BIOS). Interrupt assignment and memory usage (I/O port locations) of the PCI cards can be assigned by system BIOS only. These system resource assignments are done on a board-by-board basis. It is not suggested to assign the system resource by any other methods.

◆ PCI slot selection

The PCI card can be inserted to any PCI slot without any configuration for system resource.

2.4 PCB outline

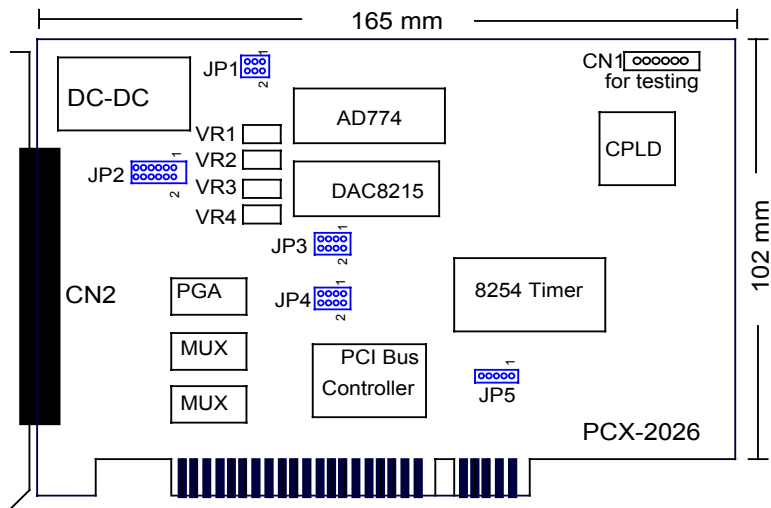

Where

- CN1: Testing only, no used for user
- CN2: Analog input/outputs and digital I/O connector
- JP1: A/D Bi-polar/un-polar and full-scale range selection jumper
- JP2: D/A output range and polar selection jumper
- JP3: A/D single-ended or differential input selection jumper
- JP4: Card number selection jumper
- JP5: Timer #0 input and output connector
- VR1: Full scale adjustment
- VR2: Bi-polar offset adjustment
- VR3: Uni-polar offset adjustment
- VR4: PGA offset adjustment

Chapter 3

Connector Pin Assignments

3.1 Analog input/output & digital input/output (CN2)

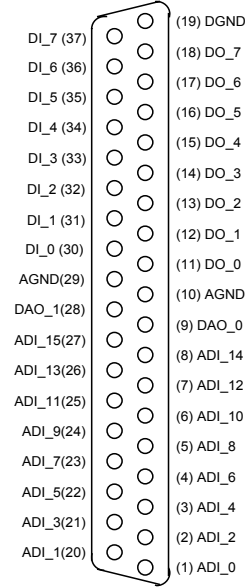
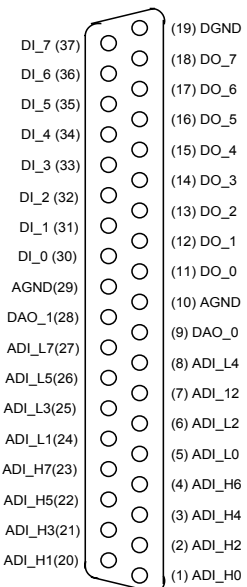
Single-ended analog input connection	Differential analog input connection
 <p style="font-size: small;"> DI_7 (37) (19) DGND DI_6 (36) (18) DO_7 DI_5 (35) (17) DO_6 DI_4 (34) (16) DO_5 DI_3 (33) (15) DO_4 DI_2 (32) (14) DO_3 DI_1 (31) (13) DO_2 DI_0 (30) (12) DO_1 AGND(29) (11) DO_0 DAO_1(28) (10) AGND ADI_15(27) (9) DAO_0 ADI_13(26) (8) ADI_14 ADI_11(25) (7) ADI_12 ADI_9(24) (6) ADI_10 ADI_7(23) (5) ADI_8 ADI_5(22) (4) ADI_6 ADI_3(21) (3) ADI_4 ADI_1(20) (2) ADI_2 (1) ADI_0 </p>	 <p style="font-size: small;"> DI_7 (37) (19) DGND DI_6 (36) (18) DO_7 DI_5 (35) (17) DO_6 DI_4 (34) (16) DO_5 DI_3 (33) (15) DO_4 DI_2 (32) (14) DO_3 DI_1 (31) (13) DO_2 DI_0 (30) (12) DO_1 DI_0 (30) (11) DO_0 AGND(29) (10) AGND DAO_1(28) (9) DAO_0 ADI_L7(27) (8) ADI_L4 ADI_L5(26) (7) ADI_L2 ADI_L3(25) (6) ADI_L2 ADI_L1(24) (5) ADI_L0 ADI_H7(23) (4) ADI_H6 ADI_H5(22) (3) ADI_H4 ADI_H3(21) (2) ADI_H2 ADI_H1(20) (1) ADI_H0 </p>

AD_n: Analog Input Channel *n* (single-ended)
AD_Hn: Analog High Input Channel *n*
AD_Ln: Analog Low Input Channel *n* (differential)
DAO_n: Analog output channel *n* / *DO_n*: Digital Output channel *n*

3.2 Timer/counter #0 (JP5)

The PCX-2026 comes equipped with one 5-pin connector – JP5 for timer/counter's signals of channel #0.

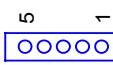
	pin-1	Pin-2	Pin-3	Pin-4	Pin-5
	Vcc	CLK	GATE	OUT	GND





Chapter 4

Jumper Setting

4.1 Card number setting



Maximum four PCX-2026 cards can be installed in system simultaneously with each has a unique card number.

A jumper called "JP4" (see page 9) on the card is used to set the card number starts from 1 to 4

JP4	Card number
	1 (default setting)
	2
	3
	4



4.2 Analog Signal Input (A/D) Type selection

JP3 is the selection jumper of analog signal input type. The following table shows the two possible configurations.

JP3	Analog signal input mode
	Single-ended
	Differential

4.3 Analog Input Polarity and Range selection

JP1 is the polarity and maximum input range selection jumper. The following table shows the two configurations.

JP1	Polarity	Maximum input range			
		Gain=1	Gain=2	Gain=4	Gain=8
	Unipolar	0V~+10V	0 ~+5V	0~0.25V	0~1.25V
	Bipolar	-5~+5V	-2.5~+2.5V	-1.25~+1.25V	-0.625~+0.625V
	Bipolar	-10~+10V	-5~+5V	-2.5~+2.5V	-1.25~+1.25V

4.4 Analog output (D/A) range selection

JP2 is the selection jumper of analog output range. The following table shows the two possible output ranges

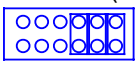
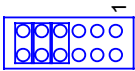
JP2	Analog Output Range
	-10V~+10V
	0V~+10V

Chapter 5

Registers Format

This information is quite useful for the programmers who wish to handle the card by low-level programming. However, we suggest user have to understand more about the PCI interface then start any low-level programming. In addition, the contents of this chapter can help users understand how to use software driver to manipulate this card.

5.1 PCI PnP Registers

There are two types of registers: PCI Configuration Registers (PCR) and Peripheral Interface Bus (PIB). The PCR, which is compliant to the PCI-bus specifications, is initialized and controlled by the plug & play (PnP) PCI BIOS..

The PCI bus controller Tiger 100/320 is provided by Tigerjet Network Inc. (www.tjnet.com). For more detailed information of PIB, please visit Tigerjet technology's web site to download relative information. It is not necessary for users to understand the details of the PIB if you use the software library. The PCI PnP BIOS assigns the base address of the PIB. The assigned address is located at offset 14h of PIB .

The 2026 board registers are in 32-bit width. But only lowest byte (bit0~bit7) is used. The users can access these registers by only 32-bit I/O or 8-bit I/O instructions. The following sections show the address map, including descriptions and their offset addresses relative to the base address.

5.2 PCI controller register address map

◆ Reset control register

The PCX-2026 is in inactive state when the system power on, and should be activated by set bit 0 of this register to "1" state

Address: Base + 0x00h

Attribute: Write only

Value: 01

◆ PCI Internal special control register

PCX-2026 internal control register, should be written with value 00H before controlling PCX-2026 card

Address: Base + 002H

Attribute: Write only

Value: always are 00H

◆ Interrupt mask control register

Enable or disable PCI interrupt INT #A

Address: Base + 005H

Attribute: Write only

Value: 10H =enable PCI INT #A, 00H=disable PCI INT #A

5.3 Digital Input Register Address Map

There are 8 isolated digital input channels on PCX-2026, each bit of based address is corresponding to a signal on the digital input channel.

Address: BASE + 0D8H

Attribute: read only

Address	Port	Bit number							
		7	6	5	4	3	2	1	0
Base+0D8H	0	DI_7	DI_6	DI_5	DI_5	DI_3	DI_2	DI_1	DI_0

5.4 Digital Output Register

There are total 8 digital output channels on the PCI-2026, each bit of based address is corresponding to a signal on the digital output channel.

Address: BASE + 0DCH

Attribute: write /read

Address	Port	Bit number							
		7	6	5	4	3	2	1	0
Base+0DCH	0	DI_7	DI_6	DI_5	DI_5	DI_3	DI_2	DI_1	DI_0

5.5 Read FIFO data register

The PCX-2026 A/D data is stored in the FIFO after conversion. The data can be transferred to host memory by software only. The register is 12 bits and can be read twice by 8 bits I/O command.

Address: Base + 0C0H ~ Base+0C4H

Attribute: Read only

Address	Bit number							
	7	6	5	4	3	2	1	0
Base+0C0H	AD_7	AD_6	AD_5	AD_5	AD_3	AD_2	AD_1	AD_0
Base+0C4H	Channel no. #n				AD_11	AD_10	AD_9	AD_8

5.6 Read FIFO status register

The PCX-2026 A/D data is stored in the FIFO after conversion. The FIFO status can be read back from this register..

Address: Base + 0D0H

Attribute: Read only

Address	Bit number							
	7	6	5	4	3	2	1	0
Base+0DCH0	X	X	X	X	BUSY	FF	HF	EF

Where:

FF: FIFO full flag

HF: FIFO half full flag

EF: FIFO empty

BUSY: '0' means AD is busy, the A/D data has not been latched in FIFO yet.
If changes from '0' to '1', A/D data is written into FIFO.

5.7 A/D control register

This register is used to set the A/D conversion control modes, such as channel number, gain, trigger, and channel scan

Address: Base + 0C0H

Attribute: Write only

Value:

Address	Bit number							
	7	6	5	4	3	2	1	0
Base+0C0H	Trigger mode	Scan mode	Gain	Channel number				

Where:

Channel Number: set A/D input channel number for conversion or auto scan ending channel

Gain: set gain (0=1, 1=2, 2=4, 3=8)

Scan mode: 0= No auto scan, the channel number will not be auto increased to next channel after current conversion completed

1=Auto scan, the channel number will be auto increased to next channel after current onversion completed

Trigger mode: 0= triggered by software, 1= Triggered by pacer

5.8 A/D control status register

This register stores the A/D conversion status such as current channel number, gain, trigger mode, and channel scan mode

Address: Base + 0CCH

Attribute: Read only

Value:

Address	Bit number								
	7	6	5	4	3	2	1	0	
Base+0CCH	Trigger mode	Scan mode	Gain	Channel number					

Where:

Channel Number: Current A/D input channel

Gain: Current gain (0,1,2,3)

Scan mode: 0= No auto scan, 1= Auto scan

Trigger mode: 0= triggered by software, 1= Triggered by pacer

5.9 Interrupt Control and Read back Register

The PCX-2026 has a triple interrupt sources,can be generated and be checked by the software. This register is used to select the interrupt sources and readback the interrupt status.

Address: Base + 0D4H

Attribute: Read / write

Value: as shown in Table 5-1

Interrupt mode	Bit number			
	7~3	2	1	0
Disable interrupt	X	0	0	0
Interrupt when FIFO is half full	X	0	0	1
Interrupt when End of A/D conversion	X	0	1	0
Interrupt when start of A/D conversion triggered by timer/counter #2	X	1	0	0

Table 5-1

5.10 Software Trigger Register

To generate a trigger pulse to the PCX-2026 for A/D conversion, you just write any data to this register, and then the A/D converter will be triggered.

Address: Base + 0C4H

Attribute: Write only

Value: any value

5.11 Hardware Interrupt Clear Register

Because the PCI interrupt signal is level trigger, the interrupt clear register must be written to clear the flag after processing the interrupt request event; otherwise, that another interrupt request is inserted will cause the software to hang on processing the interrupt event.

Address: Base + 0D8H

Attribute: write only

Value: any value

5.12 Clear scan register

This register is used to clear channel scan counter and then restart the counter from channel #0

Address: Base + 0C8H

Attribute: Write only

Value: any value

5.13 D/A control and data registers

The PCX-2026 has two 12-bit Digital to analog outputs channels. It provides uni-polar and bi-polar analog output. The I/O address map are shown below

Address: Base + 0F0H ~ Base +0FCH

Attribute: write only

Value:

Address	Function
Base+0FCH	D/A data latch control register
Base+0F0H	Low byte data of channel #0
Base+0F4H	High byte data of channel #0
Base+0F8H	Low byte data of channel #1
Base+0FCH	High byte data of channel #1

5.14 Timer/Counter Register

The 82C54 chip occupies 4 I/O address locations in the PCX-2026 as shown below. Users can refer to 82C54 data sheet for the descriptions about all the features of 82C54. You can download the data sheet on the following web site:

<http://support.intel.com/support/controllers/peripheral/231164.htm>

Address: Base + 0E0H~ Base + 0ECH~

Attribute: Read/write

Value:

Address	Timer/counter register
Base+0E0H	Counter 0 Register (R/W)
Base+0E4H	Counter 1 Register (R/W)
Base+0E8H	Counter 2 Register (R/W)
Base+0ECH	8254 control mode (W)

5.15 High Level Programming

You may bypass the detailed register structures and use provided libraries to control your PCX-2026 card directly. The software libraries, DOS library for Borland C++, and DLL for Windows 95 are included in the Inlog's "Manual & Software Utility" CD.

Chapter 6 Operation Theorem

6.1 Digital Input Channels

The digital input is TTL structure. The input voltage range are form 0V to 5V. The connection between outside signal and PCX-2026 is shown in Figure 6-1

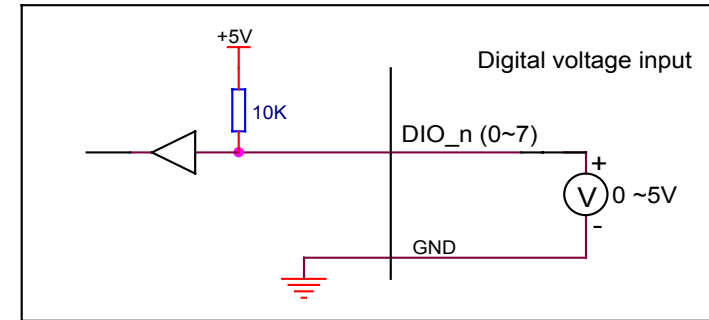

Figure 6-1 Digital inputs of PCX-2026

6.2 Isolated Digital Output Channels

On PCX-4664, digital port can be controlled by setting Base + 0DCH register (See page 17). Each output channel is TTL compatible with sink current 25mA max. The connection between outside loading and PCX-2026 outputs is shown in Figure 6-2

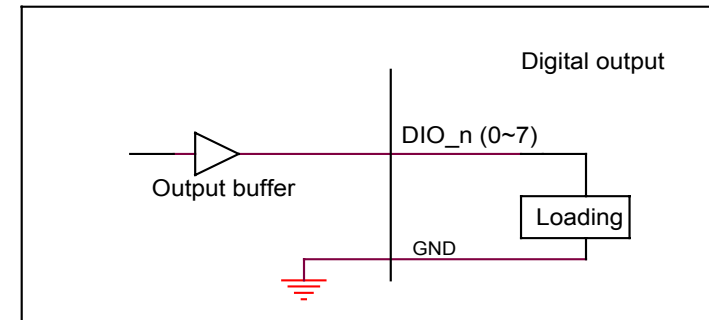

Figure 6-2 Digital outputs of PCX-2026

6.3 A/D Signal Source Control

To control the A/D signal source, User should consider the signal type, signal channel and signal range. The PCX-2026 provides 16 single-ended or 8 different isolated analog input signals. To avoid ground loops and get more accurate measurement of A/D conversion, it is quite important to understand the signal source type.

◆ Single-Ended analog input type

The single-ended mode has only one input relative to ground and is suitable for connecting with the *floating signal source*. Figure 6-3 shows the single-ended connection.

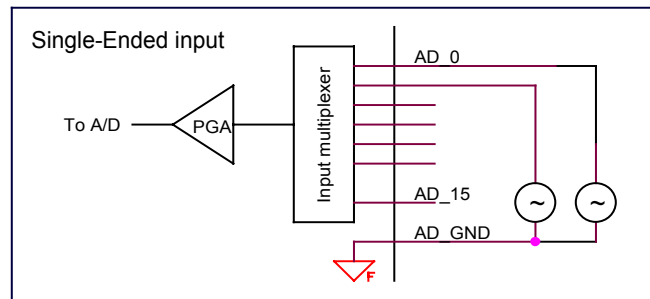

Figure 6-3 Signal sources and single-ended connection

◆ Differential analog input type

The differential input voltage signal is measured by a pair of signals. The AD circuits measure the voltage difference between the differential pair. The common mode noise can be reduced under this mode. Note that the differential signal pair should be still common ground to the isolation ground plane. Figure 4.2 shows the differential analog signal input connection.

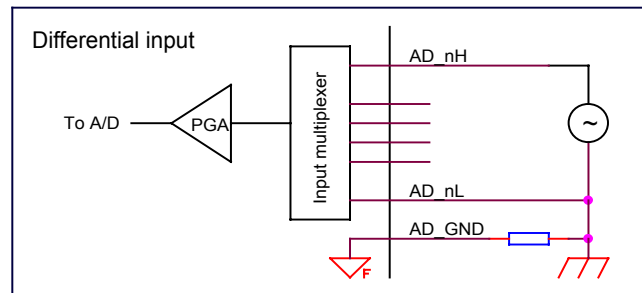

Figure 6-4 Differential analog input connection

◆ Signal Conditioning

There are 16 SE R/C filters (attenuators) on board for every channel. The RC circuits for each channel are shown in the following diagram, where 'n' is the channel number. User can install the R, C for special purpose such as attenuating the voltage to increase the input voltage range, or used as current sensor

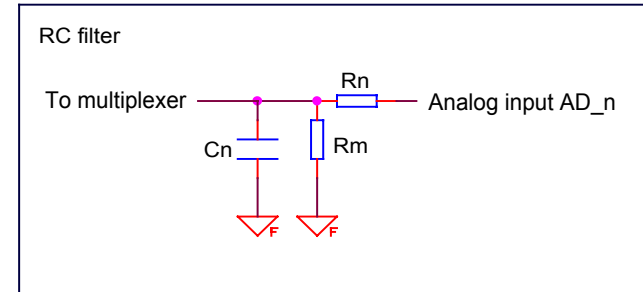

Figure 6-5

The following table shows you the corresponding RC labels for each channel. Please refer to PCX-2026 PCB

Rn	Rm	Cn	Channel number (AD_n)	
			Single-ended	Differential
R84	R66	C35	AD_0	AD_0H
R83	R67	C36	AD_1	AD_1H
R82	R68	C37	AD_2	AD_2H
R80	R69	C38	AD_3	AD_3H
R79	R70	C39	AD_4	AD_4H
R77	R71	C40	AD_5	AD_5H
R75	R72	C41	AD_6	AD_6H
R74	R73	C42	AD_7	AD_7H
R65	R15	C24	AD_8	AD_0L
R64	R16	C25	AD_9	AD_1L
R62	R17	C26	AD_10	AD_2L
R61	R18	C27	AD_11	AD_3L
R58	R19	C28	AD_12	AD_4L
R45	R20	C29	AD_13	AD_5L
R44	R21	C30	AD_14	AD_6L
R23	R22	C31	AD_15	AD_7L

Table 6-2

◆ **Signal channel control**

There are two ways to control the channel number. The first one is the software programming and the second one is the auto channel scanning, which is controlled by the SCAN mode bit in A/D control register. As SCAN mode is cleared (0), the value of AD control register bit #0~bit #3 defines the channel to be selected.

As SCAN mode is set 1, the value in control register bit #0~bit #3 defines the ending channel number of auto-scanning operation. Under auto scan mode, the channel is scanning from channel 0 to the ending channel. Whenever a trigger signal is rising, the channel number to be selected will increase automatically. For example, if the ending channel number is 8, the auto channel scanning sequence is 0,1,2,3,4,5,6,7,8,0,1,2,3,4,5,6,7,8, ..., until the SCAN mode bit is cleared.

◆ **Signal input range**

The maximum A/D signal range of PCX-2026 is a ±10 volt when the A/D gain value is 0. The A/D gain control register controls the maximum signal input range. The signal gain is programmable with 4 levels (1,2,4,8). The signal range of the 16 channels will be identical all the time even if the channel number is scanning. The available signal polarity on PCX-2026 is bi-polar and uni-polar configuration.

The following table shows you the maximum input range for each configuration



JP1	Polarity	Maximum input range			
		Gain=1	Gain=2	Gain=4	Gain=8
	Unipolar	0V~+10V	0 ~+5V	0~0.25V	0~1.25V
	Bipolar	-5~+5V	-2.5~+2.5V	-1.25~+1.25V	-0.625~+0.625V
	Bipolar	-10~+10V	-5~+5V	-2.5~+2.5V	-1.25~+1.25V

Table 6-3

6.4 A/D Trigger Source Control

The A/D converter will start to convert the signal to a digital value by a trigger source. In PCX-2026 two internal sources can be selected: the software trigger or the timer pacer trigger.

◆ **Software trigger**

The trigger source is software controllable in this mode. That is, the A/D conversion is starting when any value is written into the software trigger register. Under this mode, the timing of the A/D conversion is fully controlled by software.

◆ **Timer Pacer Trigger**

An on-board timer / counter chip 8254 is used to provide a trigger source for A/D conversion at a fixed rate. Two counters of the 8254 chip are cascaded together to generate trigger pulse with precise period. This mode is ideal for high speed A/D conversion. User can combine this mode with the FIFO half-full interrupt or EOC interrupt to transfer data. It is also possible to use software FIFO polling to transfer data. The A/D trigger, A/D data transfer and Interrupt can be set independently.

6.5 A/D Data Transfer Modes

On the PCX-2026, the A/D data are buffered in the 1024 (1K) words FIFO memory. The data must be transferred to host memory after the data is ready and before the FIFO is full. PCX-2026 provides many data transfer modes that can be used. The different transfer modes are specified as follows:

◆ **Software Data Polling**

This mode can be used with software A/D trigger mode. After the A/D conversion is triggered by software, the software should poll the FF_EF(FIFO Empty) bit of the A/D control status register. After the A/D conversion is completed, the A/D data is written to FIFO immediately, thus the FF_EF becomes high. You can consider the FF_EF bit as a flag to indicate the converted data ready status

◆ **FIFO Half-Full Polling**

The on-board 1 K words FIFO can be stored up to 10.24 ms analog data under 100 KHz sampling rate.

When the FIFO is half-full and not full, the software can read one “block” (512 words) A/D data without checking the FIFO status. This method is very convenient to read A/D in size of a “block” and it is benefit to software programming.

◆ **EOC Interrupt Transfer**

The PCX-2026 provides hardware end-of-conversion (EOC) interrupt capability. Under this mode, an interrupt signal is generated when the A/D conversion is ended and the data is ready to be read in the FIFO. After A/D conversion is completed, the hardware interrupt will be inserted and its corresponding Interrupt Service Routine will be invoked and executed. The service program can read the

converted data. This method is most suitable for data processing applications under real-time and fixed sampling rate

♦ **FIFO Half-Full Interrupt Transfer**

The FIFO half-full interrupt transfer mode is useful when the applications do not need real-time processing, but the foreground program is too busy to poll the FIFO data.

Under this mode, an interrupt signal is generated when FIFO becomes half-full. It means there are 512 words data in the FIFO already. The service routine can read a block of data every interrupt occurring. This method is very convenient to read A/D in size of a "block" (512 words) and it is benefit for software programming.

6.6 Interrupt Control

♦ **System Architecture**

The PCX-2026's interrupt system is a powerful and flexible system that is suitable for A/D data acquisition. The system interrupt can be generated by three signals: EOC, Half-Full, and Timer Pacer.

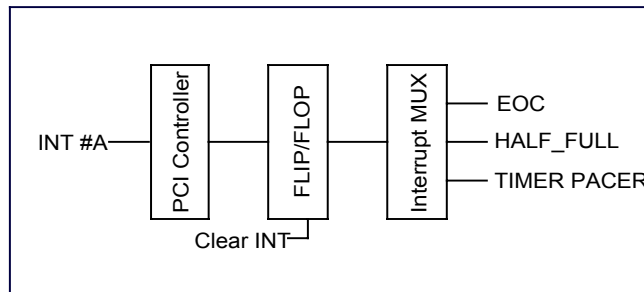

Figure 6-6

6.7 Timer/Counter Operation

One 8254 programmable timer/counter chip is installed in PCx-2026. Timer #1 and Timer #2 are used for periodically triggering the A/D conversion, and Counter #0 is left free for user applications. The block diagram of the timer/counter system is shown in the following diagram.

The timer #1 and timer #2 are cascaded together to generate the timer pacer trigger of A/D conversion. The frequency of the pacer trigger is software controllable. The maximum pacer signal rate is $2\text{MHz}/4=500\text{K}$ and the minimum signal rate is $2\text{MHz}/65535/65535$.

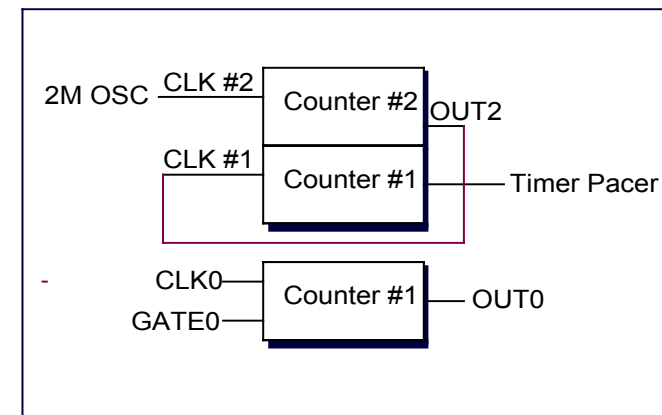

Figure 6-7

Chapter 7

Libraries

7.1 How to use the DOSDAQH.LIB in DOS

- ◆ For BC compiler
 1. Large mode : Add ..\LIB\BC\DOSDAQ.LIB in your project
 2. Huge mode : Add ..\LIB\BC\DOSDAQH.LIB in your project
 3. Include DOSDAQ.H in your source file
- ◆ For MSC compiler
 1. Large mode : Add ..\LIB\MSC\DOSDAQ.LIB in your project
 4. Huge mode : Add ..\LIB\MSC\DOSDAQH.LIB in your project
 5. Include DOSDAQ.H in your source file
- ◆ For TC compiler
 2. Large mode : Add ..\LIB\TC\DOSDAQ.LIB in your project
 6. Huge mode : Add ..\LIB\TC\DOSDAQH.LIB in your project
 7. Include DOSDAQ.H in your source file

7.2 How to use the PCIDAQH.DLL in Windows

- ◆ For VC++6.0:
 3. Add file '..\Include\PCIDAQ.H OR DOSDAQ.H' in your project
 8. In link page of menu project| setting, add '..\LIB\PCIDAQ.lib' in the blank of Objects/Library Modules
 9. Add this sentence "#include '..\Include\PCIDAQ.H OR DOSDAQ.H' " to the head of your main file.
- ◆ For Visual BASIC:
 4. Add file '..\Include\Declare.bas' in your project.
- ◆ Delphi:
 5. Add file '..\Include\Declare.pas' in your project
 10. Add this sentence "uses Declare;" in the head of your unit.pas
- ◆ C++Builder
 6. Add file '..\Include\PCIDAQ.H OR DOSDAQ.H' and '..\Lib\PCIDAQ_CB.lib' to your project
 11. Add this sentence "#include '..\Include\PCIDAQ.H OR DOSDAQ.H' " to head of your main file.

Note: For more information, please refer to program in directory'..\Example'.

7.3 Open PCX-2026 card

Description:

Because the PCX-2026 is PCI bus architecture and meets the plug and play design, the IRQ and base_address (pass-through address) are assigned by system BIOS directly. PCX-2026 cards have to be initialized by this function before calling other functions.

Syntax:

C/C++(DOS)

```
WORD D_2026_Open (WORD cardNo);
```

C/C++ (Windows)

```
WORD W_2026_Open (WORD *ExistedCards);
```

Visual BASIC (Windows)

```
Function W_2026_Open (ByRef ExistedCards As Long) As Long
```

Delphi

```
Function W_2026_Open (var ExistedCards:Integer):Integer;
```

Argument:

cardNo: Card number (1,2,3,4),It's set by jumper on card (DOS only)

existCards: The number of installed PCX-2026 cards.(Windows only). This return value shows how many PCI-2026 cards are installed in your system.

Return Code:

Error Code (Please refer to PCIDAQ.H or DOSDAQ.H)

7.4 Get card number setting

Description:

Get the cards number set by jumper on the cards.

Syntax:

C/C++(DOS)

```
void D_2026_GetCardsID(WORD *CardsIDArray);
```

C/C++(Windows)

```
WORD W_2026_GetCardsID (WORD *CardsIDArray);
```

Visual BASIC(Windows)

```
Function W_2026_GetCardsID (ByRef CardsIDArray As Long)
    As Integer
```

Delphi

```
Function W_2026_GetCardsID (var CardsIDArray:Word):Word;
```

Argument:

CardsIDArray: This array return card number (1,2,3,4) set by jumper on the cards. You should define a 4 elements array, and then pass the array's pointer to this function.

If the CardsIDArray[0] return TRUE, the card number 1 is available;

If the CardsIDArray[1] return TURE , the card number 2 is available;

If the CardsIDArray[2] return TRUE, the card number 3 is available;

If the CardsIDArray[3] return TURE , the card number 4 is available;

Return Code:

Error Code (Please refer to PCIDAQ.H or DOSDAQ.H)

7.5 Get Version of PCIDAQ.DLL or DOSDAQ.LIB

Description:

The PCX-2026 card is driven by PCIDAQ.DLL or DOSDAQ.LIB driver. This function returns the version of PCIDAQ.DLL or DOSDAQ.LIB driver

Syntax:

C/C++(DOS)

```
Void D_2026_Version (char *version);
```

C/C++ (Windows)

```
Int W_2026_Version (void);
```

Visual BASIC (Windows)

```
Function W_2026_Version () As Long
```

Delphi

```
Function W_2026_Version ():Integer;
```

Argument:

version: Stores version string when return (For DOSDAQ.LIB only)

Return Code:

The version number of PCIDAQ.DLL (Windows only)

No return (DOS only)

7.6 Close PCX-2026 card before exiting

Description:

The IRQ and base_address of PCX-2026 (pass-through address) are assigned by system BIOS directly. This function should be called to release all system resource before terminate application program

Syntax:

C/C++(DOS)

```
WORD D_2026_Close (WORD cardNo);
```

C/C++ (Windows)

```
Void W_2026_Close (void);
```

Visual BASIC (Windows)

```
Function W_2026_Close ()
```

Delphi

```
Function W_2026_Close ();
```

Argument:

None

Return Code:

None

7.7 Read data from digital input port

Description:

This function is used to read data from digital input port. You can get 8-bit digital input data from PCX-2026 by calling this function.

Syntax:

C/C++(DOS)

```
WORD D_2026_Read_Di (WORD cardNo,WORD *DiData);
```

C/C++ (Windows)

```
WORD W_2026_Read_Di (WORD cardNo,WORD *DiData);
```

Visual BASIC (Windows)

```
Function W_2026_Read_Di (ByVal cardNo As Long,  
    ByRef DiData As Long) As Long
```

Delphi

```
Function W_2026_Read_Di(cardNo:Integer;  
    var DiData:Integer):Integer;
```

Argument:

cardNo: Crd number (1,2,3,4),It's set by jumper on card
Didata: Return digital input data

Return Code:

Error code (Please refer to PCIDAQ.H or DOSDAQ.H)

7.8 Get the PCI bus and slot number of the card

Description:

Get the PCI bus and slot number occupied by the card

Syntax:

C/C++(DOS)

```
WORD D_2026_GetBusSlot (WORD cardNo, WORD *bus,WORD *slot);
```

C/C++ (Windows)

```
WORD W_2026_GetBusSlot (WORD cardNo, WORD *bus,WORD *slot);
```

Visual BASIC (Windows)

```
Function W_2026_GetBusSlot (ByVal cardNo As Long, ByRef bus As  
    Long, ByRef slot As Long) As Long
```

Delphi

Visual BASIC (Windows)

```
Function W_2026_GetBusSlot (cardNo:Integer;  
    var bus:Integer;var slot:Integer):Integer;
```

Argument:

cardNo: Card number (1,2,3,4),It's set by jumper on the card
bus: Return PCI bus Number
slot: Return PCI slot Number of the bus

Return Code:

Error Code (Please refer to PCIDAQ.H or DOSDAQ.H)

7.9 Write data to digital output port

Description:

This function is used to write data to output port. You can send 8-bit output data to PCX-2026 by calling this function.

Syntax:

C/C++ (DOS)

```
WORD D_2026_Read_Do (WORD cardNo,WORD *DoData);
```

C/C++ (Windows)

```
WORD W_2026_Write_Do (WORD cardNo,WORD Data);
```

Visual BASIC (Windows)

```
Function W_2026_Write_Do (ByVal cardNo As Long,  
    ByVal Data As Long) As Long
```

Delphi

```
Function W_2026_Write_Do (cardNo:Integer;Data:Integer):  
    Integer;
```

Argument:

cardNo: Card number (1,2,3,4),It's set by jumper on card

Data: Data be written to output port

Return Code:

Error Code (Please refer to PCIDAQ.H or DOSDAQ.H)

7.10 Read back current value of the digital output port

Description:

This function is used to read current data of output port. You can read back current 8-bit output value of PCX-2026 by calling this function.

Syntax:

C/C++ (DOS)

```
WORD D_2026_Read_Do (WORD cardNo,WORD *DoData);
```

C/C++ (Windows)

```
WORD W_2026_Read_Do (WORD cardNo,WORD *DoData);
```

Visual BASIC (Windows)

```
Function W_2026_Read_Do (ByVal cardNo As Long,  
    ByRef DoData As Long) As Long
```

Delphi

```
Function W_2026_Read_Do (cardNo:Integer;  
    var DoData:Integer):Integer;
```

Argument:

cardNo: Card number (1,2,3,4),It's set by jumper on card

Data: Return current output data

Return Code:

Error Code (Please refer to PCIDAQ.H or DOSDAQ.H)

7.11 Set a bit of digital output port

Description:

Set a bit of digital output port to active state (Output transistor ON)

Syntax:

C/C++(DOS)

```
WORD D_2026_Set_Do_Bit (WORD cardNo, WORDbitNo);
```

C/C++ (Windows)

```
WORD W_2026_Set_Do_Bit (WORD cardNo, WORDbitNo);
```

Visual BASIC (Windows)

```
Function W_2026_Set_Do_Bit (ByVal cardNo As Long, ByVal bitNo  
    As Long) As Long
```

Delphi

```
Function W_2026_Set_Do_Bit (cardNo:Integer;  
    bitNo:Integer):Integer;
```

Argument:

cardNo: Card number (1,2,3,4),It's set by jumper on card

bitNo: Bit Number(0 to 7)

Return Code:

Error Code (Please refer to PCIDAQ.H or DOSDAQ.H)

7.12 Reset a bit of digital output port

Description:

Reset a bit of digital output port to active state (Output transistor OFF)

Syntax:

C/C++(DOS)

```
WORD D_2026_Reset_Do_Bit (WORD cardNo, WORDbitNo);
```

C/C++ (Windows)

```
WORD W_2026_Reset_Do_Bit (WORD cardNo, WORDbitNo);
```

Visual BASIC (Windows)

```
Function W_2026_Reset_Do_Bit (ByVal cardNo As Long,  
    ByVal bitNo As Long) As Long
```

Delphi

```
Function W_2026_Reset_Do_Bit (cardNo:Integer;  
    bitNo:Integer):Integer;
```

Argument:

cardNo: Card number (1,2,3,4),It's set by jumper on card

bitNo: Bit Number(0 to 7)

Return Code:

Error Code (Please refer to PCIDAQ.H or DOSDAQ.H)

7.13 Initial software trigger mode

Description:

Initialize A/D conversion by software trigger, it must be called before using `W_2026_SingleChannel_AD_Acquire` or `W_2026_MultiChannel_AD_Acquire` functions

Syntax:

C/C++ (DOS)

```
WORD D_2026_AD_Acquire_Initial (WORD cardNo,WORD AD_Range);
```

C/C++ (Windows)

```
WORD W_2026_AD_Acquire_Initial (WORD cardNo,WORD AD_Range);
```

Visual BASIC (Windows)

```
Function W_2026_AD_Acquire_Initial (ByVal CardNo As Long,  
ByVal AD_Range As Long) As Integer
```

Delphi

```
Function W_2026_AD_Acquire_Initial (cardNo:Word;  
AD_Range:Word):Word;
```

Argument:

cardNo: card number to select board (1,2,3,4),It's set by jumper on card

AD_Range:AD conversion range (see page 14)

AD_Range=0: -5V ~ +5V

AD_Range=1: -2.5V ~ +2.5V

AD_Range=2: -1.25V ~ +1.25V

AD_Range=3: -0.625V ~ +0.625V

AD_Range=4: 0V ~ 10V

AD_Range=5: 0V ~ 5V

AD_Range=6: 0V ~ 2.5V

AD_Range=7: 0V ~ 1.25V

AD_Range=8: -10V ~ +10V

Return Code:

Error Code (Please refer to PCIDAQ.H or DOSDAQ.H)

7.14 Single A/D channel acquire

Description:

Single A/D channel conversion by software trigger. The function `W_2026_AD_Acquire_Initial` or `D_2026_AD_Acquire_Initial` should be called before calling this function

Syntax:

C/C++ (DOS)

```
WORD D_2026_SingleChannel_AD_Acquire (WORD cardNo,  
WORD ADChannelNo,float *ADData);
```

C/C++ (Windows)

```
WORD W_2026_SingleChannel_AD_Acquire (WORD cardNo,  
WORD ADChannelNo,float* ADData);
```

Visual BASIC(Windows)

```
Function W_2026_SingleChannel_AD_Acquire (ByVal CardNo As Long,  
ByVal ADChannelNo As Long, ByRef ADData As Single)  
As Integer
```

Delphi

```
Function W_2026_SingleChannel_AD_Acquire (cardNo:Word;  
ADChannelNo:Word; var ADData:Single):Word;
```

Argument:

cardNo: Card number (1,2,3,4),It's set by jumper on card

ADChannelNo: AD Conversion Channel (0~15).

ADData: Returned AD conversion voltage value.

Return Code:

Error Code (Please refer to PCIDAQ.H or DOSDAQ.H)

7.15 Multiple A/D channels acquire

Description:

Multiple A/D channels conversion by software trigger. The function `W_2026_AD_Acquire_Initial` or `D_2026_AD_Acquire_Initial` should be called before calling this function

Syntax:

C/C++ (DOS)

```
WORD D_2026_MultiChannel_AD_Acquire (WORD cardNo,
    WORD EndChannelNo, float *AD_Buffer);
```

C/C++ (Windows)

```
WORD W_2026_MultiChannel_AD_Acquire (WORD cardNo,
    WORD EndChannelNo, float* AD_Buffer);
```

Visual BASIC(Windows)

```
Function W_2026_MultiChannel_AD_Acquire (ByVal CardNo As Long,
    ByVal EndChannelNo As Long, ByRef AD_Buffer As Single)
    As Integer
```

Delphi

```
Function W_2026_MultiChannel_AD_Acquire (cardNo:Word;
    EndChannelNo:Word; var AD_Buffer:Single):Word;
```

Argument:

cardNo: Card number (1,2,3,4),It's set by jumper on card

EndChannelNo: AD Conversion end Channel (0~15).

AD_Buffer: Returned AD conversion voltage values.

Return Code:

Error Code (Please refer to PCIDAQ.H or DOSDAQ.H)

7.16 Initial interrupt trigger mode

Description:

Initialize range and sampling rate of AD conversion by Interrupt trigger, it must be called before `W_2026_AD_Int_StartAutoScan ()`, `W_2026_AD_Int_StartSingleChannel ()` and `W_2026_AD_Int_StartMultiChannel()` functions

Syntax:

C/C++ (DOS)

```
WORD D_2026_AD_Int_Initial (WORD cardNo,WORD AD_Range,float
    Pacer_Rate);
```

C/C++ (Windows)

```
WORD W_2026_AD_Int_Initial (WORD cardNo,WORD AD_Range,
    float Scan_Rate);
```

Visual BASIC (Windows)

```
Function W_2026_AD_Int_Initial (ByVal CardNo As Long,
    ByVal AD_Range As Long, ByVal Scan_Rate As Single)
    As Integer
```

Delphi

```
Function W_2026_AD_Int_Initial (cardNo:Word; AD_Range:Word;
    Scan_Rate:Single):Word;
```

Argument:

cardNo: card number (1,2,3,4),It's set by jumper on card

AD_Range: AD conversion range (see page 14)

AD_Range=0: -5V ~ +5V

AD_Range=1: -2.5V ~ +2.5V

AD_Range=2: -1.25V ~ +1.25V

AD_Range=3: -0.625V ~ +0.625V

AD_Range=4: 0V ~ 10V

AD_Range=5: 0V ~ 5V

AD_Range=6: 0V ~ 2.5V

AD_Range=7: 0V ~ 1.25V

AD_Range=8: -10V ~ +10V

Pacer_Rate: AD sampling rate (0.0047 to 100000 sample/sec)

Return Code:

Error Code (Please refer to PCIDAQ.H OR DOSDAQ.H)

Note:

1. Single Channel AD conversion, maximum Pacer Frequency<=110KHz.
2. Multi Channel AD conversion, maximum Pacer Frequency<=70KHZ.

7.17 Start A/D auto scan**Description:**

This function could perform A/D conversion starting from channel 0 to end channel with interrupt data transfer by using pacer trigger. It takes place in the background and will not stop until your program execute "2026_AD_Int_StopAutoScan ()" (see page 49)

The A/D data are updated periodically in the background, and you can read data by using "2026_AD_Int_GetScanData ()" (see page 48) function

Syntax:**C/C++ (DOS)**

```
WORD D_2026_AD_Int_StartAutoscan (WORD cardNo,WORD
    EndChannelNo);
```

C/C++ (Windows)

```
WORD W_2026_AD_Int_StartAutoScan (WORD cardNo,
    WORD EndChannelNo);
```

Visual BASIC (Windows)

```
Function W_2026_AD_Int_StartAutoScan (ByVal CardNo As Long,
    ByVal EndChannelNo As Long) As Integer
```

Delphi

```
Function W_2026_AD_Int_StartAutoScan (cardNo:Word;
    EndChannelNo: Word):Word;
```

Argument:

cardNo: Card number (1,2,3,4),It's set by jumper on card

EndChannelNo: Last channel (0~15).

Return Code:

Error Code (Please refer to PCIDAQ.H or DOSDAQ.H)

7.18 Get A/D scanning data

Description:

This function is used to read data from A/D scan data buffer which updated by "2026_AD_Int_StartAutoscan ()" (see page 47) function

Syntax:

C/C++ (DOS)

```
WORD D_2026_AD_Int_GetScanData (WORD cardNo,
    WORD ScanChannelNo,float *ADDData);
```

C/C++ (Windows)

```
WORD W_2026_AD_Int_GetScanData (WORD cardNo,
    WORD ScanChannelNo,float *ADDData);
```

Visual BASIC (Windows)

```
Function W_2026_AD_Int_GetScanData (ByVal CardNo As Long,
    ByVal ScanChannelNo As Long, ByRef ADDData As Single)
    As Integer
```

Delphi

```
Function W_2026_AD_Int_GetScanData (cardNo:Word;
    ScanChannelNo:Word; var ADDData: Single):Word;
```

Argument:

cardNo: Card number (1,2,3,4),It's set by jumper on card

ScanChannelNo: Scan channel (0~15).

ADDData: Returned scan AD voltage values.

Return Code:

Error Code (Please refer to PCIDAQ.H or DOSDAQ.H)

7.19 Stop auto scan

Description:

This function is used to stop the auto scan transfer function. After executing this function, the internal A/D trigger is disabled and the A/D timer is stopped.

Syntax:

C/C++ (DOS)

```
WORD D_2026_AD_Int_StopAutoscan (WORD cardNo);
```

C/C++ (Windows)

```
WORD W_2026_AD_Int_StopAutoScan (WORD cardNo);
```

Visual BASIC (Windows)

```
Function W_2026_AD_Int_StopAutoScan (ByVal CardNo As Long)
    As Integer
```

Delphi

```
Function W_2026_AD_Int_StopAutoScan (cardNo:Word):Word;
```

Argument:

cardNo: Card number (1,2,3,4),It's set by jumper on card

Return Code:

Error Code (Please refer to PCIDAQ.H or DOSDAQ.H)

7.20 Start interrupt single channel conversion

Description:

This function is used to initial and startup the AD EOC (end-of-conversion) interrupt. This function could perform single channel A/D conversion N times with interrupt data transfer by using pacer trigger. It takes place in the background and will not stop until the N-th conversion has been completed or your program execute function "2026_AD_Int_Stop()" (see page 52) to stop the process.

After executing this function, it is necessary to check the status of the operation by using the function "2026_AD_Int_Status ()" (see page 53)

Syntax:

C/C++ (DOS)

```
WORD D_2026_AD_Int_StartSingleChannel (WORD cardNo,WORD
    ChannelNo, unsigned int Count);
```

C/C++ (Windows)

```
WORD W_2026_AD_Int_StartSingleChannel (WORD cardNo,
    WORD ChannelNo, long Count);
```

Visual BASIC (Windows)

```
Function W_2026_AD_Int_StartSingleChannel (ByVal CardNo As
    Long, ByVal ChannelNo As Long, ByVal Count As Long)
    As Integer
```

Delphi

```
Function W_2026_AD_Int_StartSingleChannel (cardNo:Word;
    ChannelNo:Word; Count:Word):Word;
```

Argument:

cardNo: Card number (1,2,3,4),It's set by jumper on card

ChannelNo: Channel number (0~15)

Count: The number of A/D conversion

Return Code:

Error Code (Please refer to PCIDAQ.H or DOSDAQ.H)

7.21 Start Interrupt Multiple channel conversion

Description:

This function is used to initial and startup the AD EOC (end-of-conversion) interrupt. This function could perform multiple channel A/D conversion N times with interrupt data transfer by using pacer trigger. It takes place in the background and will not stop until the N-th conversion has been completed or your program execute function "2026_AD_Int_Stop()" (see page 52) to stop the process.

After executing this function, it is necessary to check the status of the operation by using the function "2026_AD_Int_Status()" (see page 53)

AD conversion begin from channel 0 to last channel periodically until the N-th conversion has been completed .You can use the function "2026_AD_Int_DataTransfer ()" to read AD conversion data from the buffer,

Syntax:

C/C++ (DOS)

```
WORD D_2026_AD_Int_StartMultiChannel (WORD cardNo,
    WORD EndChannelNo,unsigned int Count);
```

C/C++ (Windows)

```
WORD W_2026_AD_Int_StartMultiChannel (WORD cardNo,
    WORD EndChannelNo,long Count);
```

Visual BASIC (Windows)

```
Function W_2026_AD_Int_StartMultiChannel (ByVal CardNo As Long,
    ByVal EndChannelNo As Long, ByVal Count As Long)
    As Integer
```

Delphi

```
Function W_2026_AD_Int_StartMultiChannel (cardNo:Word;
    EndChannelNo:Word; Count:Word):Word;
```

Argument:

cardNo: Card number (1,2,3,4),It's set by jumper on card

EndChannelNo: AD Conversion end Channel (0~15).

Count: The number of A/D conversion per channel.

Return Code:

Error Code (Please refer to PCIDAQ.H or DOSDAQ.H)

7.22 Stop A/D interrupt

Description:

This function is used to stop the interrupt data transfer functions. After executing this function, the internal A/D trigger is disabled and the A/D timer is stopped.

It must be called after executing "2026_AD_Int_DataTransfer()" function.

Syntax:

C/C++ (DOS)

```
WORD D_2026_AD_Int_Stop (WORD cardNo);
```

C/C++ (Windows)

```
WORD W_2026_AD_Int_Stop (WORD cardNo);
```

Visual BASIC (Windows)

```
Function W_2026_AD_Int_Stop (ByVal CardNo As Long) As Integer
```

Delphi

```
Function W_2026_AD_Int_Stop (cardNo:Word):Word;
```

Argument:

cardNo: Card number (1,2,3,4),It's set by jumper on card

Return Code:

Error Code (Please refer to PCIDAQ.H or DOSDAQ.H)

7.23 Check A/D Interrupt status

Description:

This function is used to check the status of interrupt operation. you can issue this function to check the status of interrupt operation.

Syntax:

C/C++ (DOS)

```
WORD D_2026_AD_Int_Status (WORD cardNo,long *count);
```

C/C++ (Windows)

```
WORD W_2026_AD_Int_Status (WORD cardNo,long *count);
```

Visual BASIC(Windows)

```
Function W_2026_AD_Int_Status (ByVal CardNo As Long,  
ByRef Count As Long) As Integer
```

Delphi

```
Function W_2026_AD_Int_Status (cardNo:Word;  
var Count:Integer):Word;
```

Argument:

cardNo: Card number (1,2,3,4),It's set by jumper on card

count: The A/D conversion count number performed currently.

Return Code:

Error Code (Please refer to PCIDAQ.H or DOSDAQ.H)

7.24 Performa A/D Data Transfer

Description:

This function is used to read the A/D conversion data from A/D Data buffer which updated by functions "2026_AD_Int_StartSingleChanne ()" or "2026_AD_Int_StartMultiChanne ()"

Syntax:

C/C++ (DOS)

```
WORD D_2026_AD_Int_DataTransfer (WORD cardNo,float*
    AD_Buffer,long count);
```

C/C++ (Windows)

```
WORD W_2026_AD_Int_DataTransfer (WORD cardNo,float*
    AD_Buffer,long count);
```

Visual BASIC (Windows)

```
Function W_2026_AD_Int_DataTransfer (ByVal CardNo As Long,
    ByRef AD_Buffer As Single, ByVal Count As Long)
    As Integer
```

Delphi

```
Function W_2026_AD_Int_DataTransfer (cardNo:Word;
    var AD_Buffer:Single; Count:Word):Word;
```

Argument:

cardNo: Card number (1,2,3,4),It's set by jumper on card

AD_Buffer: Returned AD conversion voltage values.

count: The number you want to read.

Return Code:

Error Code (Please refer to PCIDAQ.H or DOSDAQ.H)

7.25 Initial and start timer/counter #0

Description:

Set 8254's timer/counter #0 with work mode and initial value.

Syntax:

C/C++ (DOS)

```
WORD D_2026_Timer0_Start (WORD cardNo,WORD TimerMode,
    unsigned int CounterValue);
```

C/C++ (Windows)

```
WORD W_2026_Timer0_Start (WORD cardNo,WORD TimerMode,
    long CounterValue);
```

Visual BASIC (Windows)

```
Function W_2026_Timer0_Start (ByVal CardNo As Long,
    ByVal TimerMode As Long, ByVal CounterValue As Long)
    As Integer
```

Delphi

```
Function W_2026_Timer0_Start (cardNo:Word; TimerMode:Word;
    CounterValue:Word):Word;
```

Argument:

cardNo: Card number (1,2,3,4),It's set by jumper on card

TimerMode: 8254's work mode, It must be 0 to 5.

CounterValue: 8254's initial value. It must be 0 to 65535.

Return Code:

Error Code (Please refer to PCIDAQ.H or DOSDAQ.H)

7.26 Read timer/counter #0

Description:

Read timer/counter #0's current counter value.

Syntax:

C/C++ (DOS)

```
WORD D_2026_Timer0_Read (WORD cardNo, unsigned int  
    *CounterValue);
```

C/C++ (Windows)

```
WORD W_2026_Timer0_Read (WORD cardNo, long* CounterValue);
```

Visual BASIC (Windows)

```
Function W_2026_Timer0_Read (ByVal CardNo As Long,  
    ByRef CounterValue As Long) As Integer
```

Delphi

```
Function W_2026_Timer0_Read (cardNo:Word; CounterValue:  
    Word):Word;
```

Argument:

cardNo: Card number (1,2,3,4),It's set by jumper on card

CounterValue: Returned counter #0's current value.

Return Code:

Error Code (Please refer to PCIDAQ.H or DOSDAQ.H)

7.27 Stop timer/counter #0

Description:

This function is used to stop the timer operation. The timer is set as the "One-shot" mode with counter value '0'.

Syntax:

C/C++ (DOS)

```
WORD D_2026_Timer0_Stop (WORD cardNo, unsigned int  
    *CounterValue);
```

C/C++ (Windows)

```
WORD W_2026_Timer0_Stop (WORD cardNo, long *CounterValue);
```

Visual BASIC(Windows)

```
Function W_2026_Timer0_Stop (ByVal CardNo As Long,  
    ByRef CounterValue As Long) As Integer
```

Delphi

```
Function W_2026_Timer0_Stop (cardNo:Word; CounterValue:  
    Word):Word;
```

Argument:

cardNo: Card number (1,2,3,4),It's set by jumper on card

CounterValue: Returned counter0's current value.

Return Code:

Error Code (Please refer to PCIDAQ.H or DOSDAQ.H)

7.28 Write data to DA

Description:

Write data to D/A output channel

Syntax:

C/C++ (DOS)

```
WORD D_2026_Timer0_Stop (WORD cardNo, unsigned int  
    *CounterValue);
```

C/C++(Windows)

```
WORD W_2026_DA (WORD cardNo,WORD DACHannelNo,  
    WORD DARange,float DAData);
```

Visual BASIC (Windows)

```
Function W_2026_DA (ByVal cardNo As Long, ByVal DACHannelNo As  
    Long, ByVal DARange as Long,ByVal DAData As Single)  
    As Long
```

Delphi

```
Function W_2026_DA (cardNo: Integer; DACHannelNo:Integer;  
    DARange: Integer; DAData: Single):Integer;
```

Argument:

cardNo: Card number (1,2,3,4),It's set by jumper on card

DA_Ch: DA channel (0 to 1)

DA_Range: DA Output Range (0=0V ~10V; 1= -10V~ +10V)

DAData:Voltage value (0V ~10.000V or -10.000V ~ +10.000V)

Return Code:

Error Code (Please refer to PCIDAQ.H or DOSDAQ.H)

Chapter 8

Calibration & Utilities

Users can calibrate the analog input channels under the users' operating environment for optimizing the accuracy. This chapter will guide you to calibrate your PCX-2026 to an accuracy condition.

8.1 Calibration

Before calibrating your PCX-2026 card, you should prepare some equipments for the calibration:

- ◆ A 5 1/2 digit multimeter (6 1/2 is recommended)
- ◆ A voltage calibrator or a very stable and noise free DC voltage generator.

8.2 VR Assignment

There are four variable resistors (VR) on the PCX-2026 board to allow you making accurate adjustment on A/D channels. The function of each VR is specified as shown below.

- ◆ VR2 A/D bi-polar offset adjustment
- ◆ VR3 A/D uni-polar offset adjustment
- ◆ VR1 A/D full scale adjustment
- ◆ VR4 PGA offset adjustment

6.1.2 A/D Adjustment

◆ PGA offset calibration

1. Set **JP3** as single-ended input
2. Short the A/D channel #0 (pin 1 of CN2) to ground (AD_GND: pin 10 of CN2).
3. Use multi-meter to measure the voltage between pin 11 of U11 and ground (AD_GND: pin 10 of CN2)
4. Adjust **VR4** until the read out value approach to zero.

◆ Uni-polar input

1. Set **JP3** as single-ended input
2. Set **JP1** as uni-polar A/D input.
3. Set **JP3** to 10V full range.
4. Short the A/D channel 0 (pin 1 of CN2) to ground (AD_GND: pin 10 of CN2).
5. Set the analog gain = 1 and channel number #0 by software.

6. Adjust **VR3** to obtain reading between 0.000~0.001.
7. Applied a +10V reference input signal to A/D channel 0, and trim the **VR2** to obtain reading approach to 9.999V

◆ Bi-polar input

1. Set **JP3** as single-ended input
2. Set **JP1** as bi-polar A/D input.
3. Set **JP3** to 20V full range.
4. Set the analog gain = 1 and channel number #0 by software.
5. Short the A/D channel #0 (pin 1 of CN2) to ground (AD_GND: pin 10 of CN2).
6. Adjust **VR2** to obtain reading between -0.001V and +0.001V
7. Applied a +10V reference input signal to A/D channel #0 (pin 1 of CN2), and trim the **VR1** to obtain reading between +9.999V.

Chapter 9

PI-837 Terminal board

PI-837 Screw-terminal termination board features one 37-pin D-type connector for easy maintenance, wiring, and installation. It provides 37 channels that are accessed through a 37-pin D-type connector.

9.1 Main features

- ♦ Low-cost screw-terminal board for the all PCX series with 37-pin D-type connector
- ♦ Reserved space for signal-conditioning circuits such as low-pass filter, voltage attenuator and current shunt
- ♦ Industrial type termination blocks permit heavy-duty and reliable signal connections
- ♦ Table-top mounting using nylon standoffs. Screws and washers provided for panel or wall mounting
- ♦ Dimensions: 80mm (W) x 181mm (H)

